

Tiny Homes – An Alternative to Conventional Housing



BC HOUSING

RESEARCH CENTRE



The NestHouse tiny house, Linlithgow, UK. Image credit: Jonathan Avery; Creative Commons

Contents

Acknowledgements	5
Executive summary	7
1 Introduction	9
What is a tiny house?	9
Design, use and placement	16
Tiny homes and other housing typologies	18
2 Tiny house users and demographics	21
Survey findings	22
User satisfaction	27
3 Housing affordability	29
The economics of building small	30
4 Opportunities	33
Quick to build	33
Go small, go green	33
Innovative technologies	37
5 Challenges	39
Political	40
Financial	40
Cultural	42
Perception and impacts on quality of life	43
6 Tiny homes, codes and standards	45
An overview: BC Building Code	48
CSA standards	49
Tiny house features and code compliance	53
Closing the gap	57
Creating a future for tiny homes	59
7 Insurance, financing and warranty	61
Insurance	63
Financing	65
Home warranty insurance and manufactures warranties	66
Moving forward	68
8 Case studies – Lessons learned	69
Case study no. 1: Bluegrass Meadows Micro Village Regional District of Kitimat-Stikine, BC	71
Case study no. 2: North Okanagan Friendship Center Society Vernon, BC	75
Case study no. 3: City of Grand Forks Grand Forks, BC	79
Case study no. 4: Caravan–The Tiny House Hotel Portland, OR	85
Case study no. 5: City of Fresno Fresno, CA	89

Case study no. 6: Boneyard Studios Washington, DC	95
Case study no. 7: Detroit Tiny Homes Detroit, MI	101
Case study no. 8: Temporary and permanent tiny house communities for people experiencing homelessness and/or low-income populations in various communities across the USA	105
Community First! Village Austin, TX	106
Othello Village Seattle, WA	108
Quixote Village Olympia, WA	111
Emerald Village Eugene, OR	114
Dignity Village Portland, OR	117
Beloved Community Village Denver, CO	120
9 Exploring BC city studies	123
City study no. 1: City of Prince George, BC	125
City study no. 2: City of Nanaimo and City of Victoria, BC	129
City study no. 3: District of Tofino, BC	135
City study no. 4: District of Squamish, BC	139
10 Conclusions and recommendations	145
11 References	147
Appendices	149
Appendix A: Tiny home user satisfaction survey	150
Appendix B: Proposed code change requests to the National Building Code	152
Appendix C: Tiny house builders' survey	153
Appendix D: City of Grand Forks—A guide in tiny houses in Grand Forks	155
Appendix E: City of Grand Forks—Development and Temporary Use Permit	157
Appendix F: Quixote Village—Funders and budget breakdown	159
Appendix G: District of Squamish—Post-workshop comments and questions	160

Acknowledgements

We thank everyone who contributed to the research, writing and editing of this report.

Research and writing team

Anastasia Koutalianos

Writer and Co-founder BC Tiny House Collective

Christina Radvak

Project Manager Light House

Joanne Sawatzky

Director of Green Building Services Light House

Sarah Jones

Project Coordinator Light House

© 2021 BC Housing, all rights reserved

BC Housing

1701- 4555 Kingsway

Burnaby, British Columbia

V5H 4V8 Canada

Notice to Readers

The greatest care has been taken to confirm the accuracy of the information contained herein. However, the authors, funder and publisher assume no liability for any damage, injury or expense that may be incurred or suffered as a result of the use of this publication including products, building techniques or practices. The views expressed herein do not necessarily represent those of any individual contributor or BC Housing. It is always advisable to seek specific information on the use of products in any application or detail from manufacturers or suppliers of the products and consultants with appropriate qualifications and experience.

Content contributors

Aaron Long, Executive Assistant and Fund Development,
Low Income Housing Institute

Amber Fogarty, President & Chief Goodness Officer,
Mobile Loaves & Fishes

Art Rodgers, Senior Housing Planner,
DC Office of Planning, Washington DC

Ben Garratt, Owner/Builder, Tiny Healthy Homes

Brigitte Martins, Master of Architecture Program,
Carleton University

Caitlin Burke, Alternative Shelter Program Specialist,
Office of Community and Civic Life, City of Portland

Cindy Moran, Research Officer
Technical Research and Education, BC Housing

Cole Chandler, Co-founder, Colorado Village Collaborative

Dan Bryant, Executive Director, SquareOne Villages

Daniel Fitzpatrick, Director of Government Relations and
Advocacy, American Tiny House Association

Dana Hawkins, Planner, District of Tofino (formerly)

David Silva, Director of Asset Strategies, Aboriginal Housing
Management Association

Engineering, Fire, Building, Operations and Planning staff at
the District of Squamish

Ian Wells, General Manager, Planning and Development,
City of Prince George

Jarred Olsen, Planner II, City of Fresno

Jaycie Osterberg, Executive Director, Quixote Communities

Karen Kehler, Tiny House Advocates of Vancouver Island

Karin Kronstal, Social Planner, City of Nanaimo

Katie Mays, Development Associate, JOIN
(formerly Dignity Village)

Kerry Hamilton, Planner, District of Squamish

Kol Peterson, Owner, Caravan–The Tiny House Hotel

Laura Roddan, Planner, Qathet Regional District

Lindsay Milburn, Senior Planner, Housing Policy,
City of Victoria

Lisa Gustaveson, Planning and Development Specialist II,
City of Seattle

Mandy Stanker, Supervisor, Current Planning,
City of Prince George

Marco Giroux, Owner, Borealis Tiny Homes

Marian McCoy, Tiny House Advocates of Vancouver Island

Mark Kohlen, Director of Sales, Honomobo

Matt Wickstrom, Senior City Planner,
Land Use Services Division, City of Portland

Max Hobbs, Tiny House Builder, Hummingbird Micro Homes

Patricia Wilson, Executive Director,
North Okanagan Friendship Center Society

Peter Thicke, Planner, District of Tofino

Respondents of the Financing, User Satisfaction and
Tiny House Builders' Survey

Reverend Faith Fowler, CEO, Cass Community Social Services

Samantha Gambling, Co-founder, BC Tiny House Collective

Scott Bucking, Assistant Professor, Department of Civil
and Environmental Engineering and the Azrieli School of
Architecture, Carleton University

Seth Reidy, Owner/Builder, Nelson Tiny Homes

Shannon Loeber, Sales Manager and Consultant,
Hummingbird Micro Homes

Shari Laliberte, Faculty/Nursing, School of Health Sciences,
Vancouver Community College

Ted Allsopp, Owner, Hummingbird Micro Homes/Bluegrass
Meadow Micro Village

Wendy Whelen, Planning Technician, City of Grand Forks

Executive summary

Over the last two decades, tiny homes have grown in popularity, but the form is not new.

Small housing, in all its iterations, has been prominent in most urban environments: from the micro apartments of Asia, micro-suites of North America, to the small spaces of Europe and everywhere in between. And yet, in the late 1990s the world was drawn to builder Jay Shafer's introduction (if not reintroduction) of the tiny house on wheels. Perhaps it was a nod to the foregone days of caravan travel trailers, or more importantly, an acknowledgment of a collective desire for a simpler way of life that was more accessible, affordable and sustainable than mainstream housing options.

The media soon jumped on the trend and our screens are now full of programming on all things small: *Tiny House Builders*, *Tiny House*, *Big Living* and *Tiny House Nation*. We are invited into the minds of designers, builders and future homeowners—all seeking their own solutions for change, each with their own story to tell. Some wanting to live with less or to downsize their lifestyle; others wanting small in reaction to the unattainable housing market that continues to rise in cities across Canada.

All the while, tiny houses still struggle to find a place in urban and rural landscapes. At present, most communities in British Columbia¹ do not allow anyone to live permanently in a tiny house on wheels. This raises these questions: Is the form viable? Is it affordable? And to whom does this lifestyle appeal?

In 2018, [BC Housing](#)², [Light House](#)³ and the [BC Tiny House Collective](#)⁴ began exploring this topic more thoroughly in hopes that this research could advance knowledge, and pave a way forward for municipal governments, industry, future homeowners, and the public to better understand this form and the feasibility of tiny houses.

A tiny house, as defined in this report, is a permanent ground-oriented dwelling that is detached, moveable and non-motorized, under 500 square feet and tailored to compact design. It is neither a mobile home nor a recreational vehicle (RV). It is a home intended for full-time living. Our research shows that in North America these houses are more similar to other viable, safe and code-compliant housing forms than first imagined. Equally, they offer practical and economical options for a number of unique demographics, including people who choose to live alone, those experiencing homelessness, and those seeking a minimalistic and/or transient lifestyle. Tiny houses are not only a millennial fad. In fact, survey findings in the US and Canada show they are most favoured by single women in their 50s.⁵

This report also shares the challenges of this form: code and standard compliance (structural, fire, plumbing, seismic), zoning, financing and tenure, and political and public support. Our findings demonstrate that cities are taking steps to further explore the typology, and some tiny communities are now fully developed, supported and thriving. To tackle this discussion, the economics and basic principles of tiny living, and the challenges and opportunities of these homes are explored in more detail. Several tiny house forms were reviewed as part of this study. These consist of various foundation options, including temporary (on a chassis/flat deck), more permanent and flexible models such as concrete slabs, and concrete piers and blocks, as well as on wheels (or moveable as referred to in this report), prefabricated and container units.

¹ Exemptions include most First Nations reserve land or some regional districts (with the exception of Agricultural Reserve Land)

² BC Housing; bchousing.org/home

³ Light House; light-house.org/

⁴ BC Tiny House Collective; bctinyhousecollective.com/

⁵ See Section 2 of this report for more on tiny house users and demographics. Mitchell, Ryan. "State of the Tiny House Union—2015." *The Tiny Life*; thetinylife.com/tiny-houses

The research methodology was qualitative in nature and included: three surveys on user satisfaction, financing and tiny house construction, a multi-stakeholder workshop, and over fifty online and phone interviews with builders, designers, policy makers, financiers, urban planners, tiny house advocates and city staff from across Canada and the United States. This report also includes two case study sections. The first section features existing projects or villages in 13 communities, each with their own story and lessons to share (see pages 69 to 121).

Topics include issues related to city planning and tiny homes, temporary homeless encampments, Indigenous home design contests and intentional permanent villages.

The second section explores case studies in five B.C. municipalities (Prince George, Nanaimo, Tofino, Squamish, and Victoria) and outlines the challenges and solutions with tiny homes in each community (see pages 123 to 143).

All case studies were carefully selected to demonstrate variety in terms of tiny house type, use, demographics, location/geography, funding and partnership models, and outreach methods.

The findings of this report demonstrate that tiny homes—although currently challenged by existing codes, standards, financing and insurance—can be a viable typology for the “missing middle,” and for individuals who aspire to attain detached single-family homeownership. Further work is required to make tiny homes a safe and compliant housing form, and therefore, local and provincial governments are encouraged to:

1. Consider tiny homes as an allowable dwelling unit and a viable typology to address the “missing middle” that can assist in delivering affordable homeownership and increase rental options across B.C.
2. Reassess affordable housing strategies and include tiny homes in the provincial building code and in official community plans.
3. Explore tiny homes as a form of emergency shelter in response to natural disasters and homelessness, when housing needs are most immediate.
4. Investigate ways to regulate and legalize this housing form, and its associated industry, so that those who choose to live tiny can champion safety, quality and innovation.

These initiatives will help navigate the tiny typology from non-compliance to a regulated and safe construction market via new industry standards and actionable government support, which in turn, will provide more opportunities for tiny homeownership, financing and insurance coverage. See Conclusions and Recommendations.

1 | Introduction



Tiny house community. Image credit: Droomparken, Netherlands

Tiny homes continue to grow in popularity and interest across the globe. However, their viability as an alternative housing form is often questioned. This section provides a high-level overview of what a tiny house is, its design features, potential uses and placement. It compares tiny homes to other forms to show how they fit in the greater conversation about housing affordability and accessibility.

What is a tiny house?

There is no single definition of a tiny house.

For the purpose of this research, we are expanding on the working definition of the [BC Tiny House Collective](https://www.bctinyhousecollective.com/)⁶, the province's public voice on the typology. In this report, we define **a tiny house as: a ground-oriented permanent dwelling that is detached, moveable and non-motorized, small in size (less than 500 square feet) and using a compact design.**

Often, we limit tiny homes to wood-framed units that are built on a chassis or flat deck (on wheels) only. However, this report

also explores prefabricated (modular) and converted steel shipping container units—all of which can be constructed, assembled or placed on either temporary, flexible or permanent foundations.

Note: This report uses the term *moveable* over *mobile* as it relates to tiny homes in order to differentiate it from the mobile home typology.

⁶ BC Tiny House Collective; [bctinyhousecollective.com/](https://www.bctinyhousecollective.com/)

TINY HOUSE FORMS AND FOUNDATION TYPES

Note: These images are for reference only. Foundations and tiny house types can be used interchangeably.

Moveable tiny house

On wheels (flexible foundation)

As per Transport Canada guidelines, a tiny house placed on an 8-foot trailer cannot exceed a width of 8.6-feet, including all siding and soffits (the roof's overhang), and a height of more than 13.6 feet. A tiny house that is 10-feet wide requires a special permit and tow truck to move from one location to another.

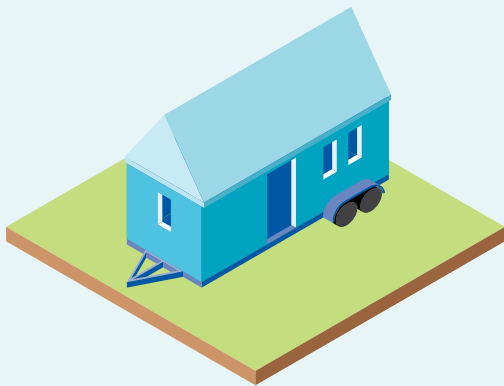

Prefab and containers

On helical screw piles (temporary foundation)

Both modular and prefabricated homes are methods of factory-built construction. However, they are not synonymous terms. Prefabricated consists of panelized construction, where parts or the entirety of a building is built in a factory to defined specifications, and later transported and assembled on-site. Modular refers to a type of construction where an entire unit is built and assembled off-site. The module is later transported and placed on a foundation as a stand-alone unit or attached to other modules. See Section 6: Tiny Homes, Codes and Standards.

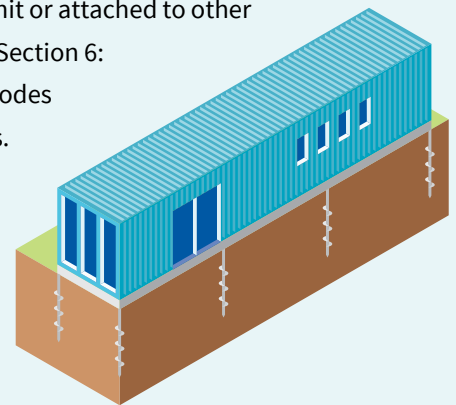

Modular tiny house

On concrete slab foundation (permanent foundation)

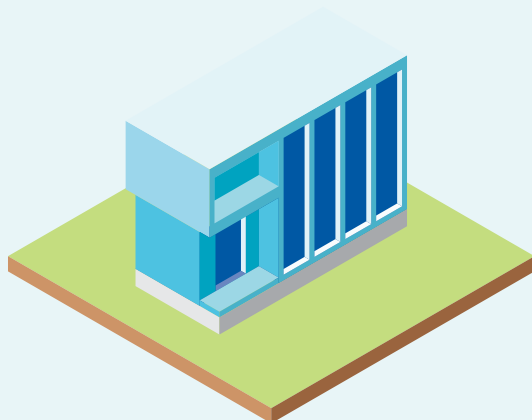

On concrete piers (flexible foundation)

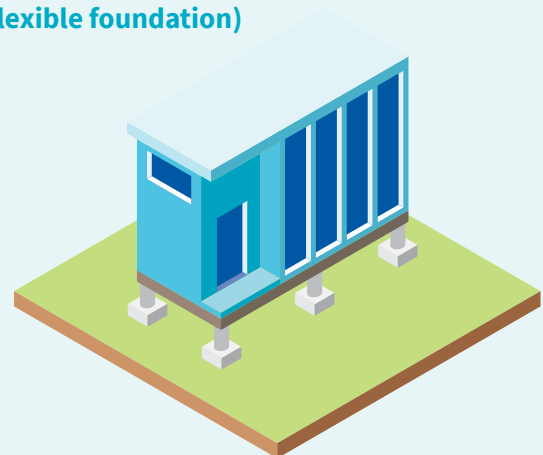

Based on our definition of a tiny house, this section offers more detail on their characteristics.

› GROUND-ORIENTED

Unlike micro-suites or apartments, tiny homes are ground-oriented units. They can be anchored or skirted to meet seismic and character retention (aesthetics) requirements or to mitigate animal access into the home. Tiny house units can also be stacked as demonstrated in the Oneesan container housing project developed by Atira Women's Society in Vancouver⁷.

Anchors or steel rods secure the base of the tiny home to the ground. The purpose of anchors is not to make the unit more stable, but to facilitate seismic bracing and to prevent possible theft and tipping in high winds. The soil type determines the type of anchor needed.

Skirting is the application of insulating material around the bottom of a structure to reduce exposure to cold air under the trailer. Depending on cost and location, some skirting options include rigid foam, vinyl siding, corrugated metal, plywood sheets, bales of straw (which can hold moisture) or snow in colder climates.



View of the Oneesan building from the interior courtyard.

Image credit: Atira Women's Society

Anchoring and skirting a tiny house on wheels

TYPES OF ANCHORS

- › Concrete deadman anchor
- › Auger anchor
- › Drive anchor
- › Hard rock anchor
- › Anchors in concrete slab

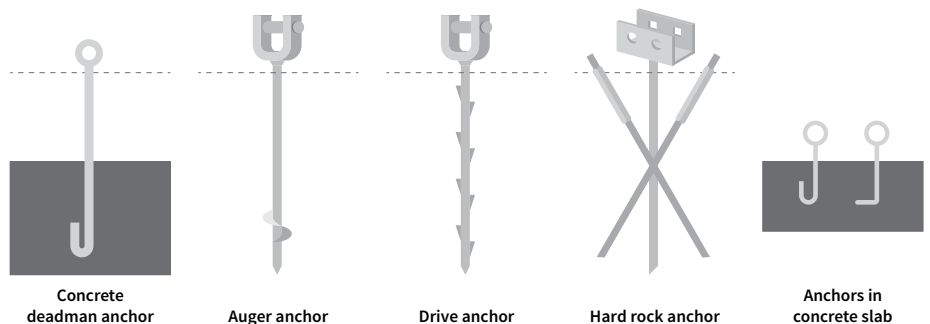

⁷ JTW Consulting. "Oneesan Container Housing Project." *Atira*; atira.bc.ca/sites/default/files/Container%20Housing%20Report%20FINAL.pdf

How to anchor a moveable tiny house

1. Determine soil type and select anchors accordingly.



2. Level the tiny house (and remove wheels).

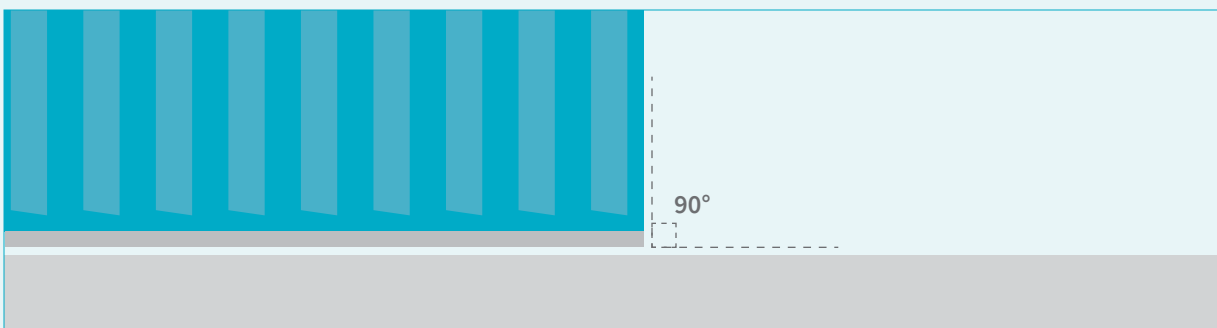

3. Select hookup—an over-the-top or frame tie-down system (can be vertical or diagonal). Each will require its own hookup and tensioning device.

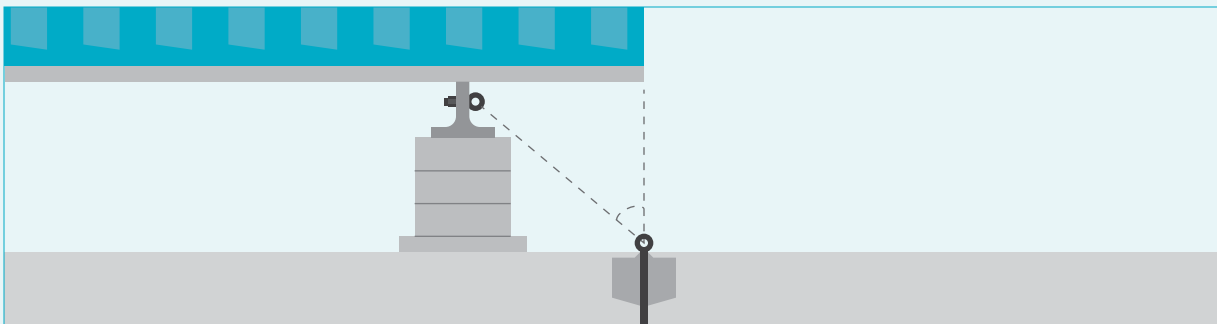

4. Add steel strap, fasten around the frame of the trailer, and attach to the anchors with adjustable bolts. Alternating from side to side, adjust your tie-downs to the appropriate tension.

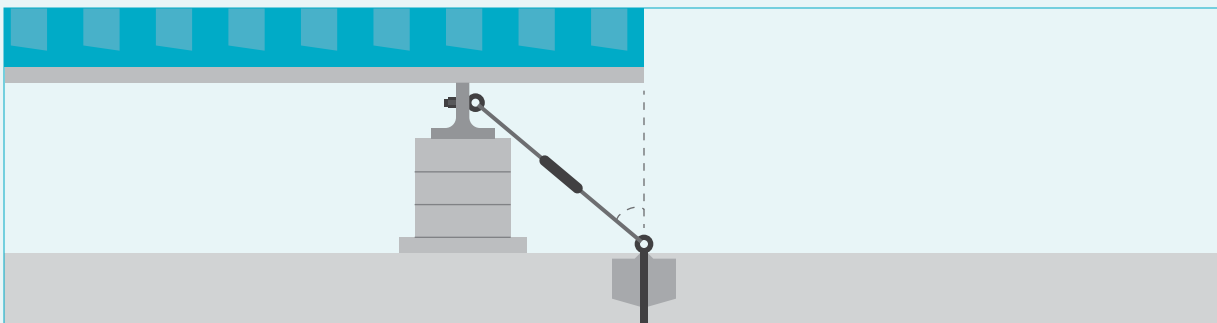

› PERMANENT DWELLING

By design, a tiny house is intended for year-round living by one or more persons. It contains the same amenities as any full-sized home, float home, apartment/condo, and micro or lock-off suite. This includes a space to cook, eat, live, sleep and wash—qualifying the unit as a dwelling unit⁸ as outlined in the BC Building Code (BCBC). From this perspective, a tiny house is intended as a primary-use residence and should not be considered a recreational vehicle (an RV), which is a motorized travel vehicle designed for temporary-use only.

› DETACHED UNIT

A tiny house is a standalone unit that can be placed individually on a lot, in the backyard of a single-family dwelling as a laneway home⁹. It can also be placed within a pocket village—that is, multiple units placed on a single piece of land with shared amenities or communal space, such as a community garden or common area with kitchen facilities, laundry and/or extra bedrooms. Tiny houses can also share exterior walls, similar to a rowhouse development; this design reduces heat loss and can make the housing unit more sustainable.

› MOVEABLE

While many are built on wheels, some tiny homes use prefabricated designs or shipping containers as their frame. All three of these models provide flexibility in terms of assembly and placement. See page 10 for more on foundation types.

Temporary or flexible foundations, such as a flat deck, allow the tiny house unit to be built directly onto the chassis and then moved to one location, with options to re-locate it. Pier or pile foundations can accommodate the same moveability without too much additional infrastructure. These options may suit certain geographical areas that are prone to flash floods where quick movement is favourable, as well as regions that require emergency response shelters due to fire or other natural disasters.



Interior of a container unit. Image credit: ContainerWest



Grantham house. Image credit: Click Modular Homes



Rochette tiny house (wheels removed and levelled). Image credit: Tiny Healthy Homes

⁸ The 2012 British Columbia Building Code defines *dwelling unit* as a “suite operated as a housekeeping unit, used or intended to be used by one or more persons and usually containing cooking, eating, living, sleeping and sanitary facilities”

⁹ A laneway house is a detached unit typically in the backyard of a primary residence on a single-family lot. Also known as an accessory dwelling unit or ADU, carriage house, caretaker cabin, and/or granny or garden suite. Note: These terms are used interchangeably throughout this report

Temporary foundations should be considered for their mobility and also because they are more affordable and environmentally-friendly than concrete-intensive practices.

A chassis can range in size and price, offering homeowners many choices, while still being more economical than laying down a concrete foundation (see Table 2 on page 31); pier and pile foundations remove the flat deck altogether from the build, and can reduce project costs by up to 20%, depending on the size of the trailer. Note, a slab-on-grade base requires heavy machinery, larger crews, removal of earth, trips to the landfill, and can impact groundwater and inhibit leaching.

A chassis can serve as both a foundation and as a means to move the unit to site where it can be anchored and used for full-time living. Concrete piers or piles can lift the unit off the ground and work well on various soils and rocky conditions, that might not be well suited for a wheeled-base home. This option still requires skirting of some kind.

“If they are on wheels, we’d need to see them differently. On wheels, we’d need to distinguish them from a vehicle.”

—Matt Wickstrom, Senior City Planner, Land Use Services Division, City of Portland

Ultimately, budget, location, and needs dictate many of these choices. It’s worth re-emphasizing that the chassis can facilitate easier transportation. Yet unlike a travel trailer, its sole purpose is not to keep the house in constant motion. From this perspective, the moveable tiny house is inherently more sustainable—assuming it is seldomly towed and not over great distances. It is closer to its cousin the mobile home, which is a fixed permanent dwelling, rather than an RV.

› NON-MOTORIZED

A tiny house, in all its iterations is a moveable unit. Each requires a vehicle for it to be moved—either by a conventional truck, tow truck or on a flat deck truck depending on the width and length of the unit, and whether it is prefabricated, a container or wood-framed (and on wheels). (Note: Some units may require a crane depending on their size and placement.) This also differs from an RV, which often combines a living space within a motorized vehicle.

TRAILER TERMS

Gooseneck: Trailer slides over a ball hitch in the bed of a pickup truck; known for its stability

Fifth wheel: Trailer attaches to a pickup truck using a hinged plate hitch

Bumper pull (aka drag or tagalong trailer):

The trailer’s tongue fits over a ball hitch that jets out from the pickup’s frame at the rear of the vehicle

Deck height: Height from the ground to the top of the trailer or flat deck

TYPES OF TRAILERS (CHOICE DEPENDS ON WEIGHT/ SIZE OF TINY HOUSE)

Single versus double (or tandem) axle trailers:

Double axles have two axles placed close to one another to help disperse the weight of the load; while a tandem axle can carry more, a single axle trailer weighs less and therefore is easier to manoeuvre and more economical to tow

Drop axle trailer: 21-inches from ground to the deck

Regular axle trailer (straight): 24-inches from ground to the deck

Deck over trailer (fenders are under the floor): 32-inches from ground to the deck

› SMALL SIZE AND COMPACT DESIGN

On average, tiny houses are 300 square feet or more. They are similar in size to micro apartments, smaller condos, lock-off suites, float homes and houseboats. Each uses flexible furniture and space-saving features like lofts and double-duty storage to increase functionality within their smaller footprints. Apart from float homes and houseboats which are also moveable, the only difference between tiny houses and these other built forms is that tiny homes are ground-oriented, and not intended for low/high-rise or water living.



The BC Tiny House Collective includes the ability to customize as a key feature to tiny homes. While this is not unique to tiny homes, the form is easily tailored to the owner's tastes and needs, given the limited size of the unit's components. This can include adding more expensive materials and options such as intentional design, green technologies, and waste management systems like composting or incinerating toilets, rainwater and greywater filtration systems. They may include the use of sustainable products such as reclaimed building materials and recycled appliances. All of which are in line with the greater tiny living movement.



Interior photos of the Cascadia tiny house on wheels. Image credits: Tiny Healthy Homes

Design, use and placement

DESIGN

Like traditional single-family homes, tiny houses come in all shapes, sizes, colours and styles—from country rustic to ultra modern and sleek. Here are two typical layouts:

1. The unit is built as a bungalow all on one level. This is most conducive for universal design and for those who may require more floor space, should they have limited mobility, need an accessible unit, or are not interested in having a second floor or loft with ladder or staircase access.
2. Two storeys, with sleeping quarters on the second level, accessed by a ladder or staircase. Neither the loft area, nor the space under it is at full ceiling height, otherwise the unit cannot be moved under Transport Canada regulations. These height restrictions, however, do not apply to non-wheeled units that can be transported to site and remain permanently fixed to a foundation of choice.

Within these parameters, there are thousands of creative and innovative tiny house designs with layout and furniture playing dual roles. For instance, sofas converting into extra bedding, tables serving as both desks and dining areas, greywater filtration tanks or extra storage in floor joists.



Moveable tiny house used as a business in Carcross, Yukon. Wheels remain on the unit and a boardwalk is built around it so they aren't visible at first glance

PRIMARY USES

- › Principal residence
- › Emergency shelter
- › Vacation home or rental
- › Business or sales centre (for real estate, product showcase or visitor/tourism offices)
- › Workshop/artist studio
- › Food truck



Tiny house as a principal residence. “Beautiful Tiny House in an Eco Community” by Living Big In A Tiny House; youtube.com/watch?v=LDwS0EIJJqc&list=PL999ZDYL8QbTqnT8PZshZzJa7tat-Vdcj&index=4&t=0s



Tiny house as a studio. “Artist Builds his Savannah Studio with Shipping Containers” by Kirsten Dirksen; youtube.com/watch?v=9QNPB9naZQg

PLACEMENT OPTIONS

- › The tiny house unit is the primary residence and only dwelling on the site
- › The unit is placed on a permeable pad (gravel or concrete slab) in the front or rear yard of a single-family lot as a traditional accessory dwelling unit (ADU) or ADU alternative
- › The tiny home is placed temporarily on an irregular parcel of land that is awaiting a Development Permit or is leased through a private owner or the city
- › The unit is part of a community development (multiple units on one site) with shared amenities and communal areas
- › Units are stacked in a low-rise development (if using prefabricated or container units)

TENURE TYPES

- › The land is privately owned by the tiny homeowner
- › The land is privately/publicly owned (city/land trust) and rented/leased to the tiny homeowner
- › The land is strata-titled, privately owned and/or rented to the tiny homeowner

Tiny online

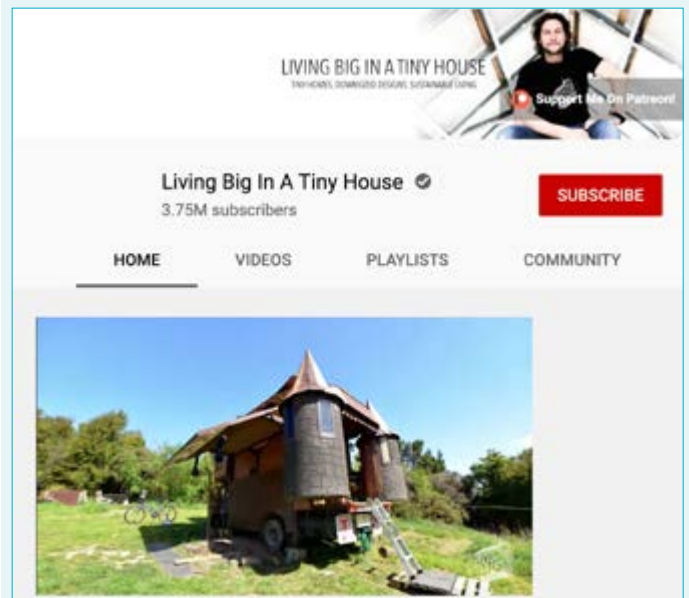

Living Big In A Tiny House features countless tiny house designs and layouts from across the globe. The YouTube channel, launched in 2013, has over 2.17 million subscribers and over 254 million views as of August 22, 2019; youtube.com/user/livingbigtinyhouse



A community of tiny houses. Image credit: Quixote Communities



Tiny house used as a laneway. Image credit: Christine Dong, Willamette Week

Tiny homes and other small housing typologies

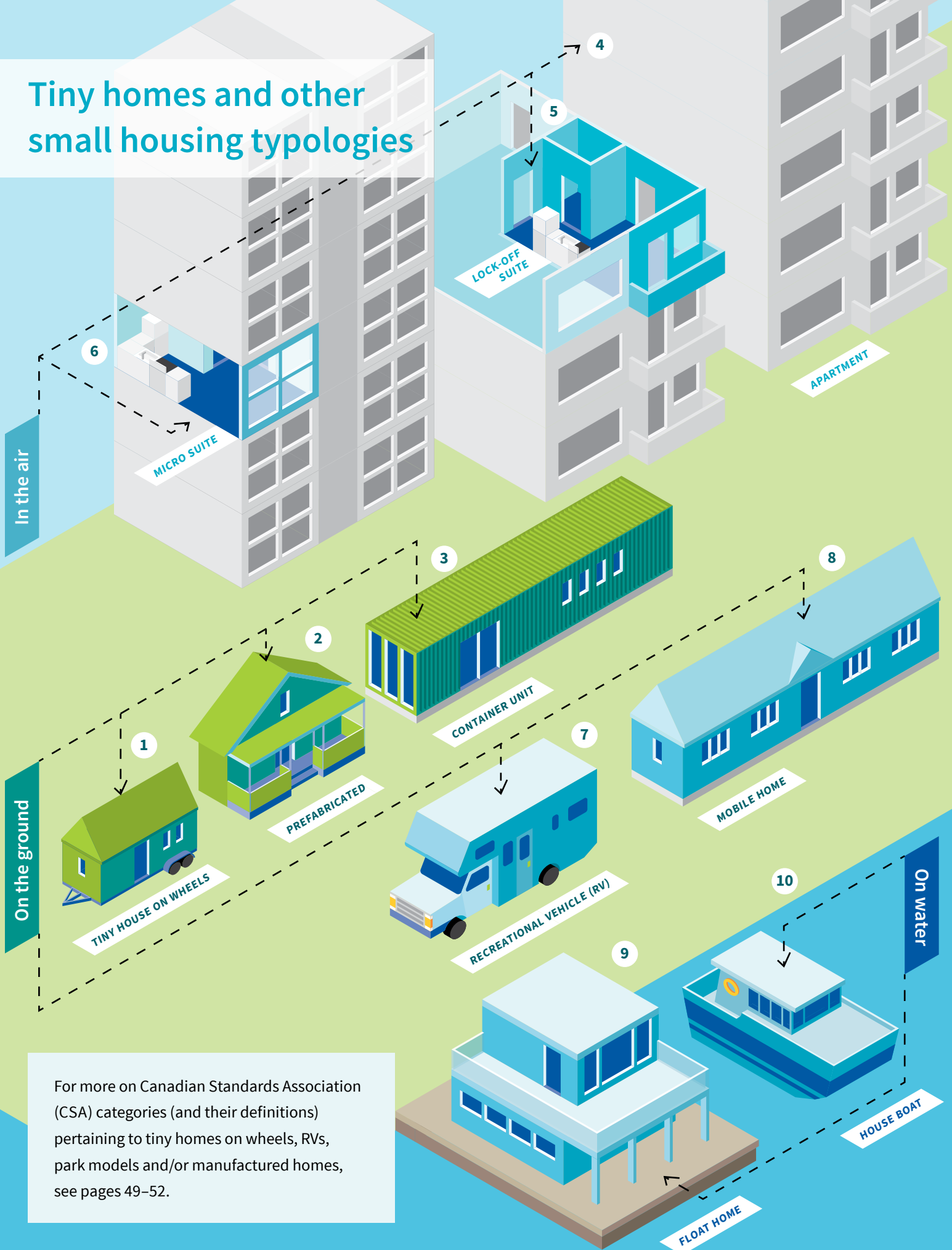

For more on Canadian Standards Association (CSA) categories (and their definitions) pertaining to tiny homes on wheels, RVs, park models and/or manufactured homes, see pages 49–52.

Tiny homes should not be viewed in a league of their own. Many of their structural and design features are widely replicated in other housing typologies that are viewed as both safe and legal from a building and code perspective. This table outlines them in more detail:

TABLE 1. TINY HOMES AND OTHER HOUSING TYPOLOGIES

NO.	TPOLOGY	DESCRIPTION	ORIENTATION	UNIQUE FEATURES	SIMILARITIES TO TINY HOMES	CODES/STANDARDS
1	Wood-framed on wheels/ chassis (tiny house)	Wood-framed unit built on a flat deck	Ground-oriented	› Foundation and home, in one	-	› CSA-Z240-RV › CSA-Z241
2	Prefabricated (tiny house)	Product built off-site and transported and assembled on-site; a modular process	Ground-oriented or multi-storey	› Factory-built; reduces waste	-	› BCBC ¹⁰ compliant › CSA-A277
3	Container unit (tiny house)	Retrofitted metal shipping container	Ground-oriented	› Repurposed steel structure › Concern over prior use and/or materials in unit	-	› Unknown
4	Apartment (including condo)	A self-contained housing unit in a building that includes various-sized units	Low/high-rise	-	› Permanent dwelling › Creative use of space › Shared amenities	› BCBC compliant
5	Lock-off suites	An apartment that has been converted into two separate units; a fully self-contained apartment within an apartment (has own amenities including a kitchen and bathroom), that can become one unit again when needed. Requires own entrance from the hallway; originated at Simon Fraser University	Low/high-rise	› May use interior courtyards to provide light to both units › Income unit within a low/ high rise apartment	› Permanent dwelling › Small in size › Creative use of space	› BCBC compliant
6	Micro-suite	Ultra small apartments that are typically less than 320 square feet and contain all basic amenities	Low/high-rise	-	› Permanent dwelling › Small in size › Creative use of space › Multipurpose furniture › Shared amenities	› BCBC compliant
7	Recreational vehicle	A vehicle that combines transportation and temporary living accommodations for travel, recreation and camping	Ground-oriented	› Must be licensed through ICBC as a recreational vehicle; for seasonal living only	› Mobile › Part of community	› CSA-Z240-RV
8	Mobile home	A prefabricated modular structure built in a factory and transported to site; also known as a trailer home	Ground-oriented	› Ability to inspect product and sign-off on requirements	› Permanent dwelling › Moveable › Foundation options › Part of a community	› BCBC compliant › CSA-A277 › CSA-Z240-MH
9	Float home	Permanent dwelling built on a floating apparatus; needs assistance to move (tugboat)	On water	› Stair steepness › Narrow features	› Detached permanent dwelling › Contains structural elements that are not BCBC-compliant › Part of community (if at dock/ moored) › Towable › May use alternative waste management systems	› BC Float Home Standard ¹¹
10	Houseboat	A boat that has its own means of propulsion and movement; they have seaworthy hulls, engines and fuel	On water	› Small sleeping quarters › House and boat in one	› Use of alternative waste management systems, such as compost toilets › Towable	› Unknown

¹⁰ BC Building Code

¹¹ Many components or building practices within tiny homes are contested and non-compliant with the BC Building Code. It is worth exploring which elements within float homes are also found in tiny homes but have received compliance through their own standard, the British Columbia Float Home Standard: gov.bc.ca/assets/gov/farming-natural-resources-and-industry/construction-industry/building-codes-and-standards/guides/2003_float_home_standard.pdf



*Bluegrass Meadows Micro Village, Regional District of Kitimat-Stikine, B.C. Image credit: Bluegrass Meadows Micro Village
Refer to Case Study No. 1 to learn more*

2 | Tiny house users and demographics



*People in line for the tiny house tour at the Go, Go TINY event in May 2017 at Science World in Vancouver.
Image credit: BC Tiny House Collective*

Who lives tiny and is most drawn to this form and lifestyle?

Contrary to popular belief, tiny houses are not a millennial fad. According to surveys from across British Columbia and the United States, single women in their 50s are the main user of this housing type. This population cohort is typically well educated, has disposable income, and is building tiny as a first-time homeowner, or as a step towards retirement. See survey findings below.

Survey findings

Here are findings from three surveys: thetinylife.com (USA, 2013¹² and 2015¹³), and the BC Tiny House Collective (Canada-wide, 2017).

THE TINY LIFE SURVEYS

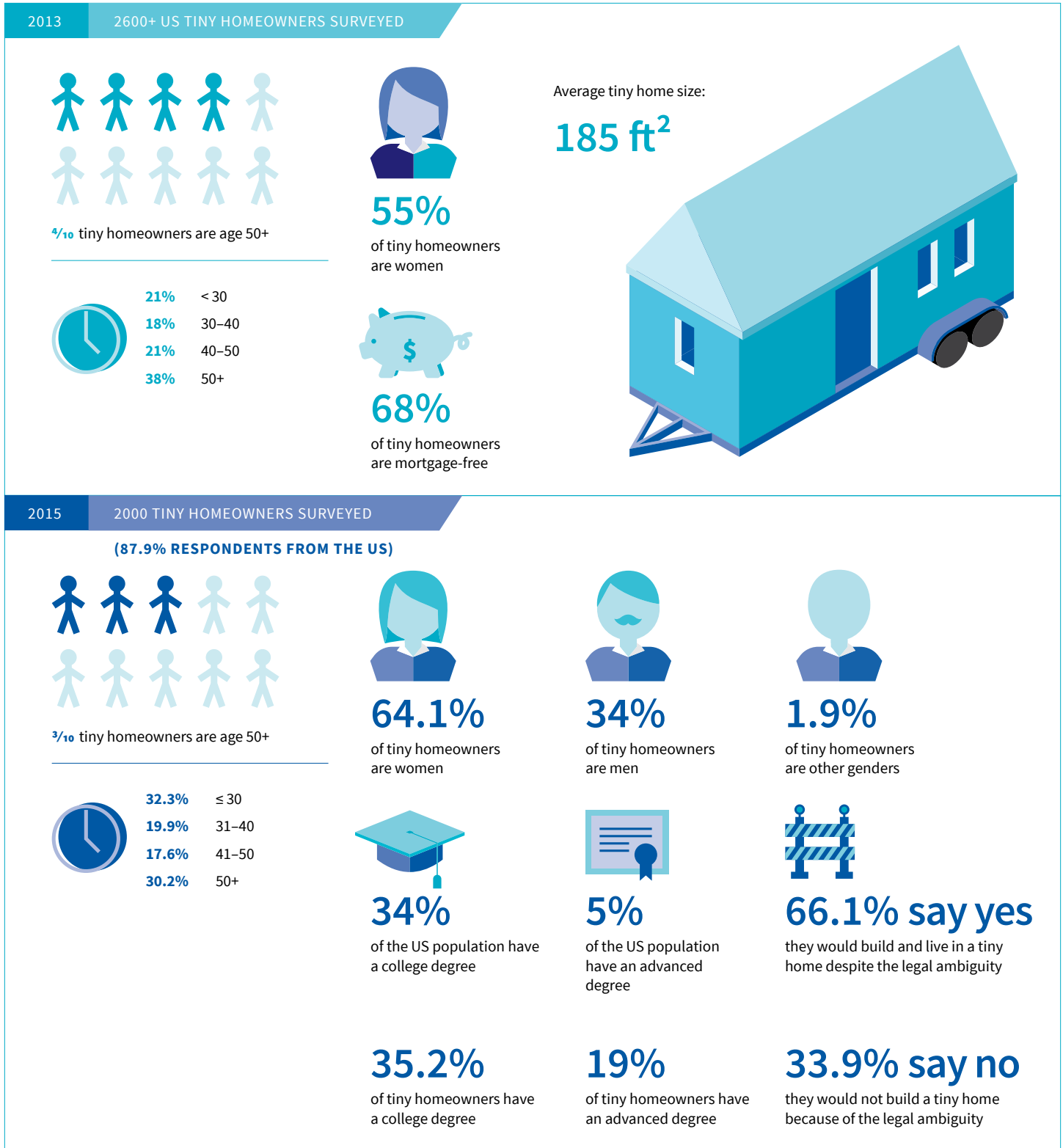

¹² 2013; thetinylife.com/tiny-house-infographic/ | ¹³ 2015; www.thetinylife.com/tiny-houses

BC TINY HOUSE COLLECTIVE SURVEY

The BC Tiny House Collective (BCTHC) carried out a survey over six months in 2016–2017 to investigate the demand and support for tiny houses in Metro Vancouver, and more generally across B.C. and Canada. Data was collected through an online questionnaire and shared with media and through BCTHC’s website and social media channels. Responses were collected mainly from the Greater Vancouver Area. 1,013 responses were used for analysis purposes. Data was analyzed by University of British Columbia (UBC) graduate students in the Masters of Food and Resource Economics program in the summer of 2017. Here’s what the BCTHC found:

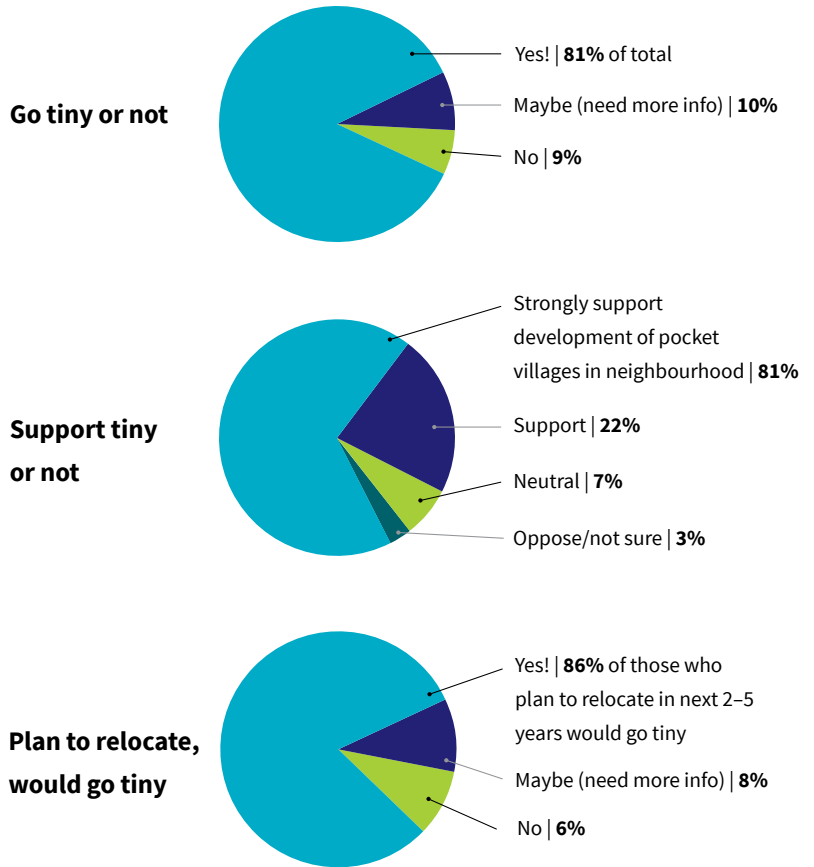

Overview

Respondents and their ages

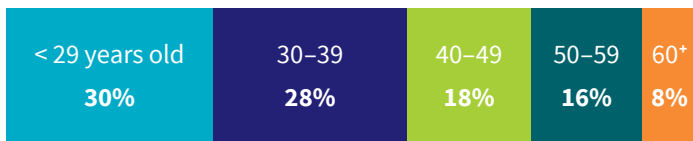

Preferred community amenities

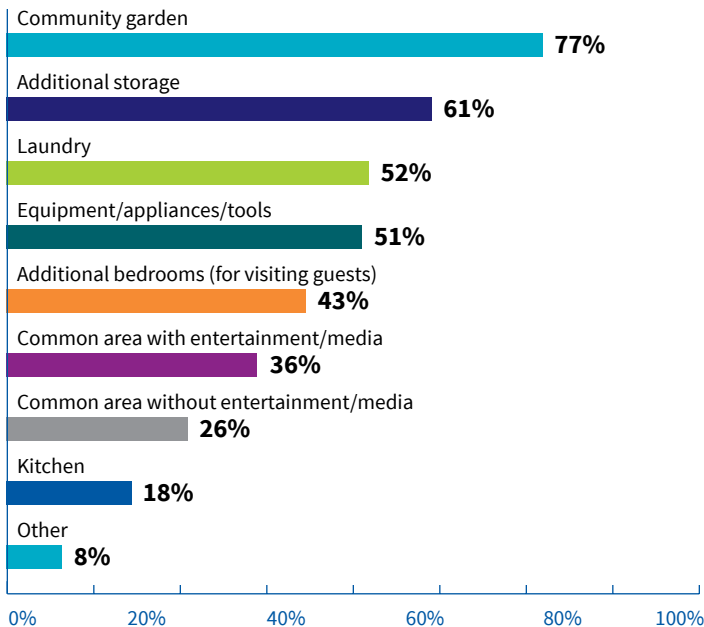

Reasons to go tiny

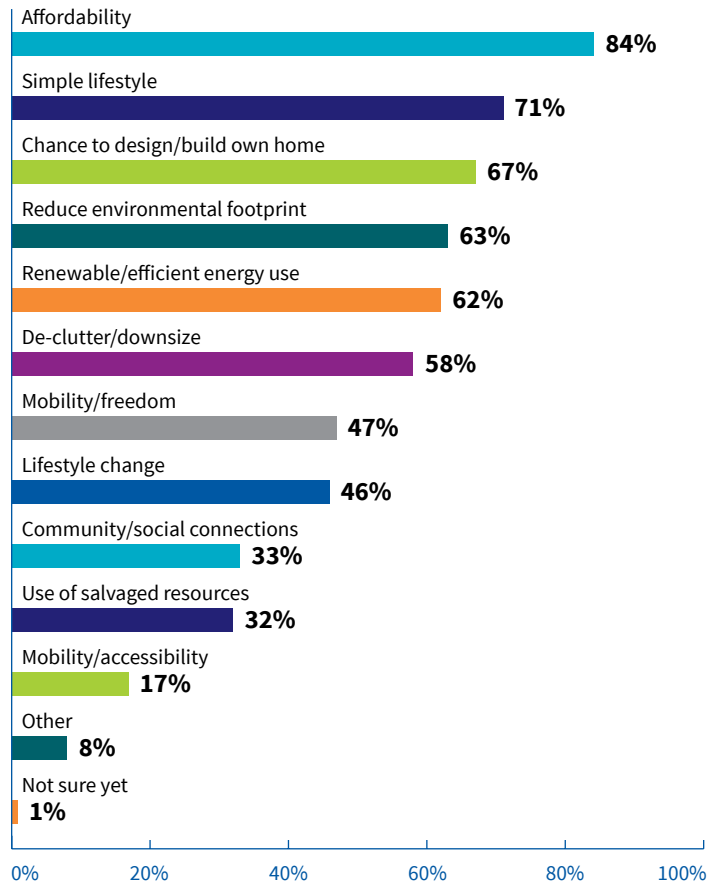

BCTHC survey in-depth

1,013 Respondents

CHARACTERISTICS OF SURVEY RESPONDENTS

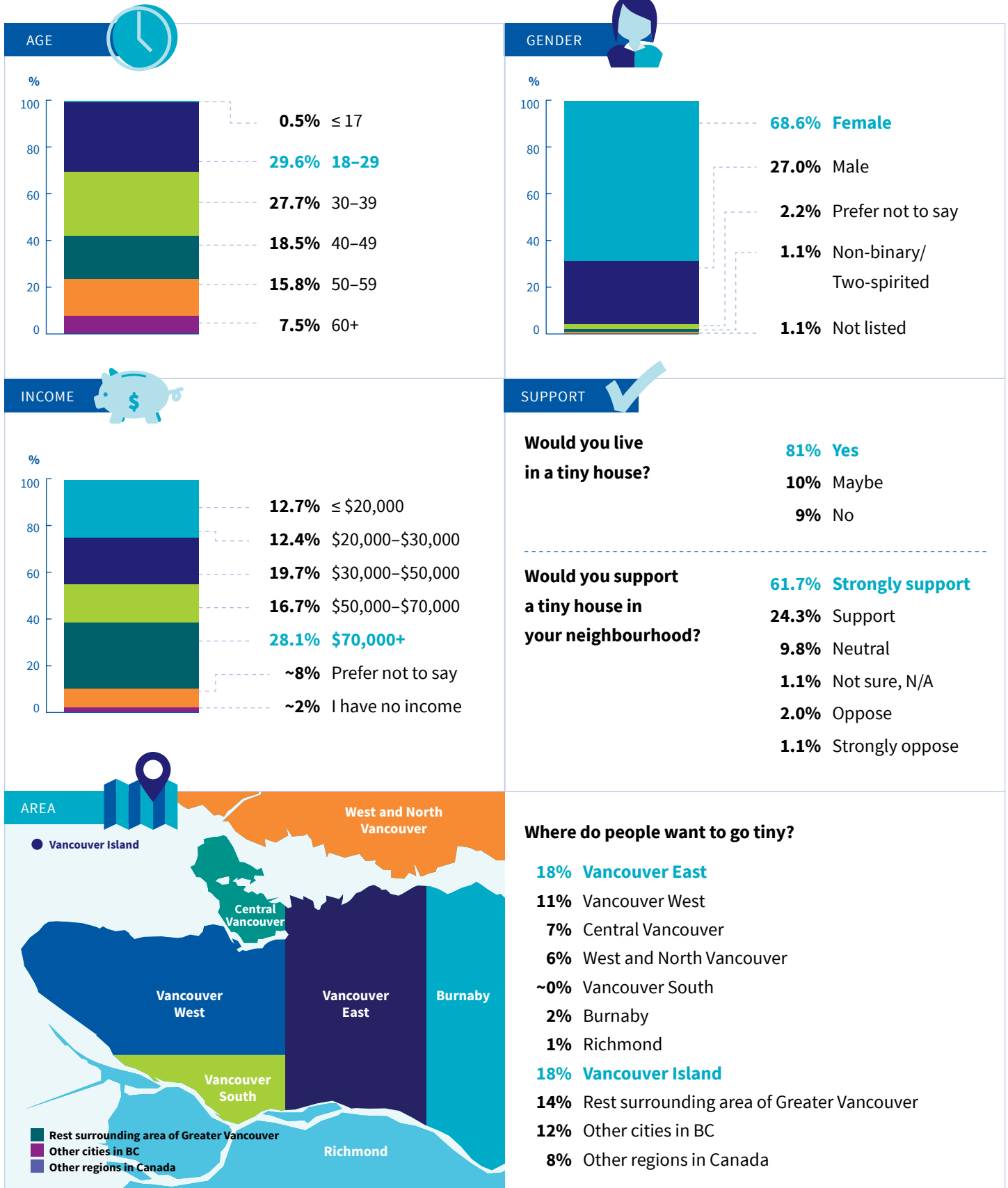

SUPPORT: HOW MANY SUPPORT TINY HOUSES?

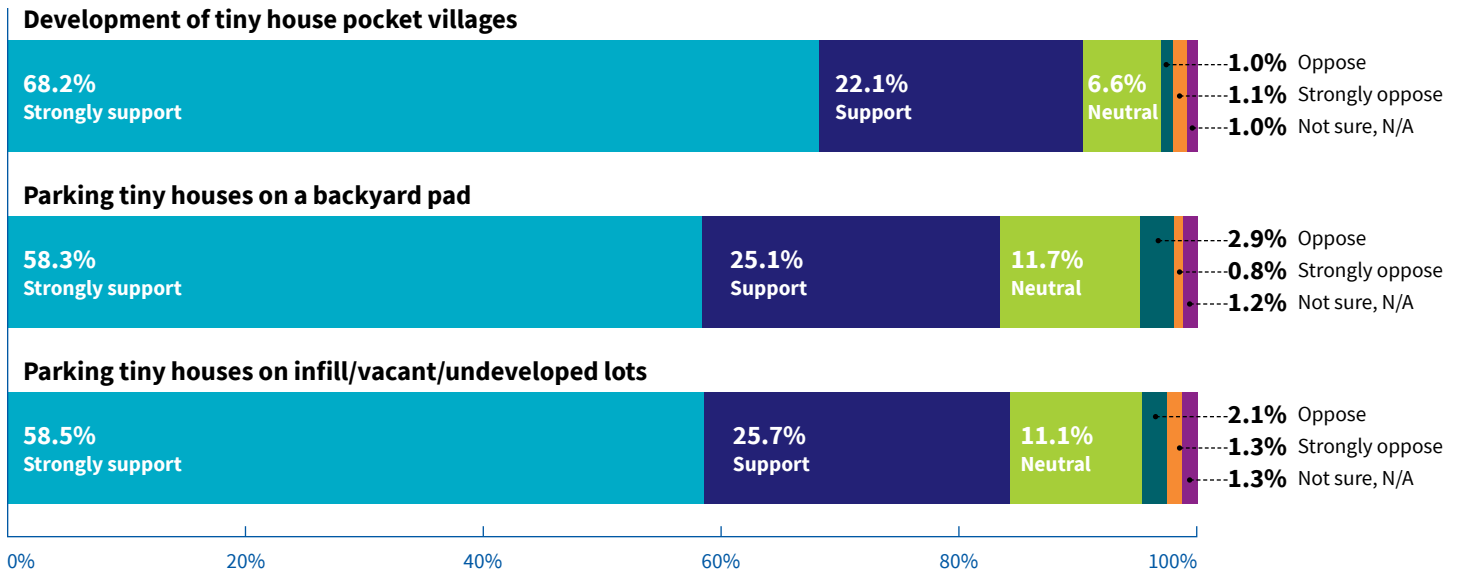

MOTIVATION: WHAT ARE THE REASONS FOR LIVING IN A TINY HOUSE?

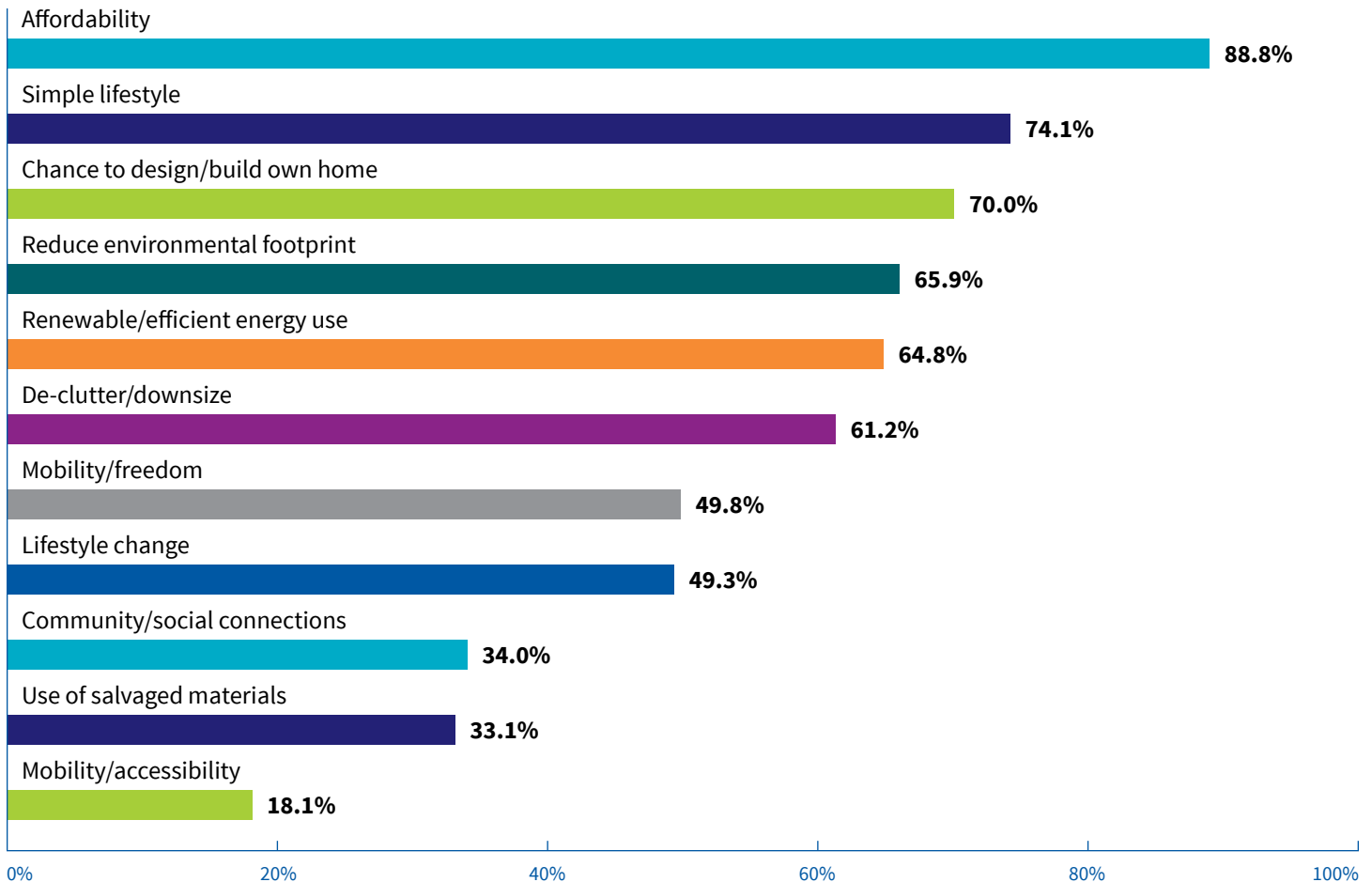

BUILDING: WHAT ARE THE TOP FIVE PREFERRED SHARED AMENITIES?

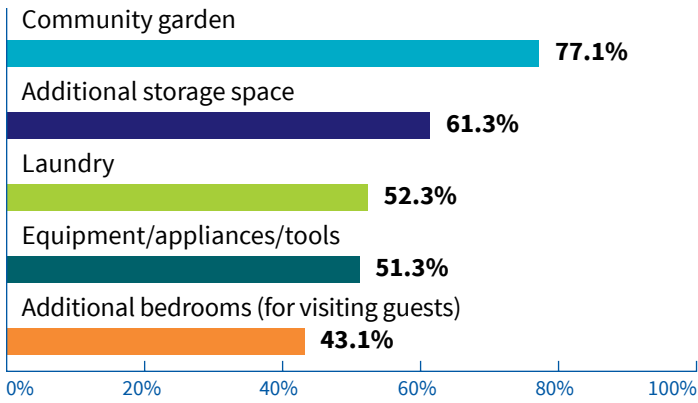

WHAT ARE THE TINY HOUSE SIZES PREFERRED BY RESPONDENTS?

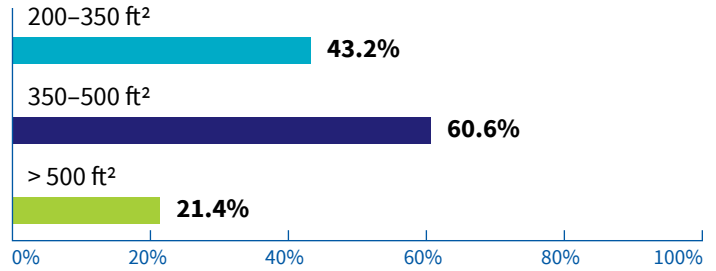

PARKING: WHERE DO PEOPLE WANT TO PARK THEIR TINY HOUSES?

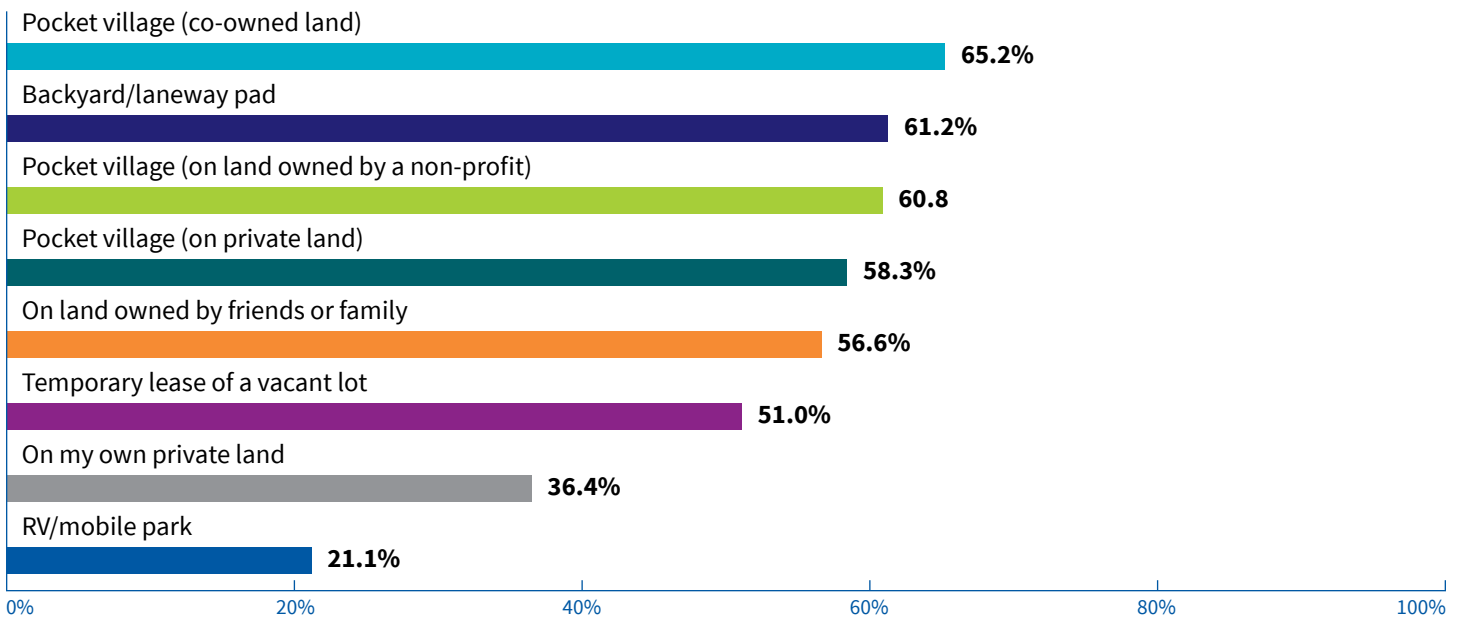

FINANCE: HOW DO PEOPLE WANT TO FINANCE THEIR TINY HOUSE PLAN?

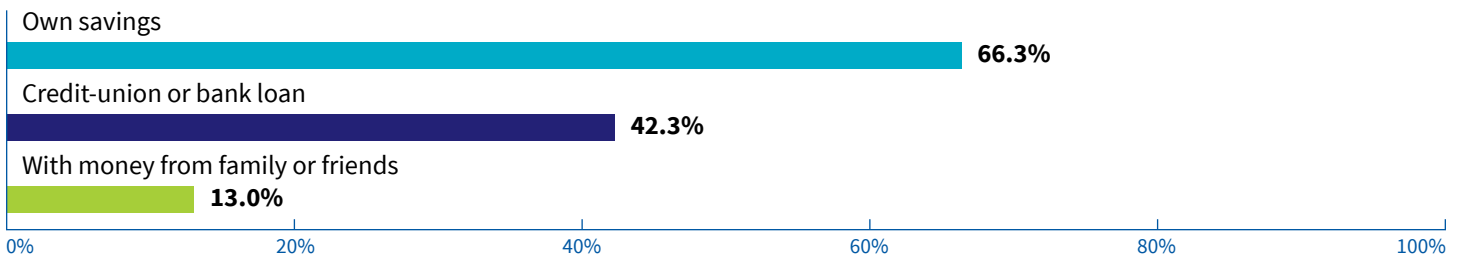

OWNERSHIP: HOW DO PEOPLE WANT TO ACQUIRE THEIR TINY HOUSE?

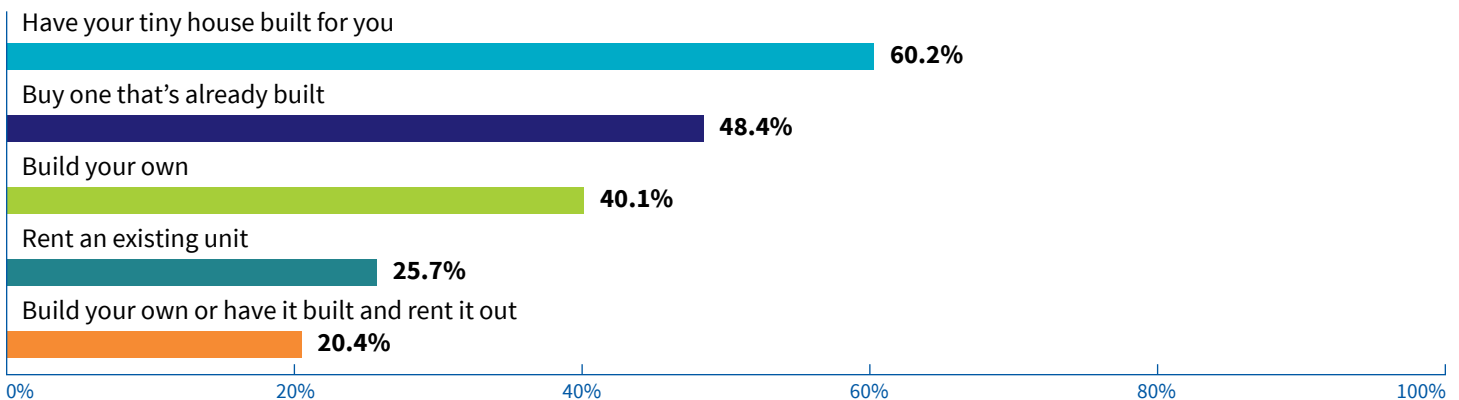

User satisfaction

As part of this report’s research methodology, a survey was produced and shared among tiny homeowners to gauge their quality of life and see whether anecdotal literature and survey findings matched the actual experiences of those living tiny. What did they enjoy about their homes? What did they wish was different or better? It addressed the following key areas:

- › Personal overview and current living situation: occupation, roommates and pets
- › Previous and current living situations
- › Details of their tiny house, including design features and foundations
- › Distance to local amenities
- › Financing and financial cost of living in a tiny house
- › Overall satisfaction with the unit, its placement and impacts on quality of life (social, career)

Personal tiny tales



Visit the Tiny House Expedition’s YouTube page for more personal accounts on why individuals, couples and families are drawn to tiny homes: youtube.com/channel/UCmpHOZ6GqCvcWyPX3svgz-g/videos

Exploring Alternatives is a channel about designs and uses: youtube.com/user/explorealternatives



Tiny house viewing. Image credit: Delta Bay, California

The questionnaire was distributed within communities tailored to house people experiencing homelessness or hard-to-house in the United States, tiny villages in Canada, as well as with individuals who were renting land around regional districts, or those illegally parked as ADUs within B.C. city limits.

19 responses were received over a one-month period; 18 respondents are currently living in their tiny houses.

Note: Participants represent a variety of socio-economic backgrounds. Personal information of all participants is anonymous to protect privacy.

Survey respondents experienced two main challenges: insecurity of tenure and placement, and unit size.

- 1. Tenure and placement:** For those that do not live in a designated or intentional tiny home community, there is constant stress of relocation. Often tiny houses are parked outside municipal boundaries where there is less of a worry of eviction. However, residents can be far from amenities, which makes everyday living more challenging. Even though there is security in homeownership, the logistics of where to place a tiny house is onerous for individuals committed to the tiny home lifestyle.
- 2. Unit size:** Individuals who live in a tiny house out of necessity (in this case, formerly homeless) feel it is too small. These respondents plan to move into larger accommodations in the future.

In summary, residents feel safe in their tiny homes and feel there is little negative impact on their social lives or careers. The units provide a sense of autonomy in times when securing stable housing may be challenging. However, tiny living is not for everyone. It can indirectly elicit insecurity and perceived isolation, given that one cannot legally park and live in a tiny house within city limits. Others find it too small.

From the limited number of responses received, all agreed that living in a tiny house improved their quality of life.

For more survey findings, see Appendix A in this report.

“I have space for a garden right beside my house, which is wonderful. I live in a community with other tiny homes/RVs, and that community is the best part of this location. I do love being able to live off- grid and use my composting toilet to turn back [my waste] into usable manure for the forest and garden. I love having a porch that extends my living space to the outdoors. But it’s so far from anything else.”

—Anonymous, user satisfaction survey respondent, 2019



Tiny house in Portland, Oregon. Image credit: Tammy, Weekend With Dee; Creative Commons

3 | Housing affordability



Grantham house. Image credit: Click Modular Homes

How does a tiny house fit into the greater discussion on housing affordability?

Tiny homes provide a unique opportunity for affordable homeownership, that can separate the cost of the structure from land value. This differs from conventional homeownership, which is often associated with acquiring property. One of the main benefits of tiny houses is that they are not permanently secured to one property. Their mobility allows them to be parked on a site that has been purchased by the homeowner, or on rented land. If land cost becomes too expensive, the tiny house can be relocated to a lot within budget.

However, mobility alone will not make these homes more accessible. Their affordability¹⁴ is often contested, particularly when calculating the costs of installing tiny homes in urban centers where land values continue to rise.

¹⁴ Canada Mortgage and Housing Corporation (CMHC) defines affordable housing as costing less than 30% of a household's before-tax income

The economics of building small

At first glance, building small requires less materials and costs less. However, there are a few other factors to consider. There is no one-size-fits-all tiny home. A tiny house is no different than any other permanent dwelling; it requires the same hookups and fixtures of a single-family home, apartment, condo or micro-suite. For instance, it must be connected to the electrical system and have a kitchen and bathroom. There are a number of stories of tiny houses constructed on a shoestring budget, however, these are not the norm. They have sparked confusion over how much it costs to go tiny. Much of this has to do with erroneous information, and the rise of a do-it-yourself culture that may sidestep codes or regulations.

There are six key factors that influence the overall construction cost of a tiny house (and any house for that matter): design, materials, location, labour, unit size, and time (speed of delivery).

Design: Design and materials go hand in hand. A complicated intricate design with high-end materials costs more. Special configurations such as a universal design or a staircase versus a ladder may add more to the budget. The quality, number of windows and doors, and the type of tiny house in general—be it on wheels, prefab or a shipping container—is also a factor. Every style comes with its own unique expenses.

Materials: The use of non-structural reclaimed building materials, such as reclaimed wood, cabinets and counters, may save some builders money; while new and high-end ones naturally come with a bigger price tag.

Location: Geography may increase the budget too, especially when factoring in transportation of goods that may not be as readily accessible as in larger markets and cities. There are also costs associated with securing land and tying into municipal services, or going off-grid.

Labour: Labour costs vary based on location, season and access, and whether parts of the project can be done in-kind, discounted or self-contracted. Tiny house owner-builder construction is still a very contested topic, especially when it comes to code compliance and safety.

Unit size: Size equally impacts cost, not only in terms of trailer and foundation type, but whether it needs to be towed or craned onto site.

Time (speed of delivery): An expedited build may require more money upfront, particularly if hiring a professional tradesperson or builder.

Estimates¹⁵ on building costs for a moveable, prefabricated or container unit tiny house can be found in Table 2:

Table 2 disclaimer: These are estimates. Geography, a builder's experience, and access to labour and materials greatly impact construction costs, along with factors already mentioned. While we have provided a range of sizes, smaller units may not be permissible in municipalities that have minimum size requirements. If they are allowed, they may fall under the category of a building structure and not a permanent dwelling. In this case they will not require a permit or compliance to any code or standard.

¹⁵ Tiny house cost estimate sources: Tiny Healthy Homes (Vancouver), Hummingbird Micro Homes (Fernie), Borealis Tiny Homes (Prince George) and Nelson Tiny Houses (Nelson); modular and container source: Honomobo (Edmonton)

TABLE 2. COSTS TO BUILD A TINY HOUSE ON WHEELS, MODULAR AND AS A SHIPPING CONTAINER

Note: All cost estimates are in Canadian funds, 2018. Rents may fluctuate based on city and market influences. See page 32 for assumptions.

Wood-framed tiny house (on wheels/chassis)				
ITEM	SIZE & TRAILER DIMENSION (LOFT SPACE ACCOUNTED)			
	100–200 square feet 8.5 x 20 with/without 50 sf loft	200–300 square feet 8.5 x 26 with 75 sf loft	300–400 square feet 8.5 x 2 with 100 sf loft	400–500 square feet 10 x 36 with 140 sf loft
Construction				
Materials including appliances	\$22,000–\$25,000	\$26,000–\$32,000	\$36,000–\$42,000	\$42,000–\$50,000
Flat deck	\$5,000	\$8,000	\$12,000	\$16,000
Labour				
Plumbing	\$5,000	\$5,000	\$5,000	\$6,000
Electrical	\$3,000–\$5,000	\$4,000–\$6,000	\$5,000–\$7,000	\$5,000–\$9,000
Gas	\$2,000–\$5,000	\$2,000–\$5,000	\$2,000–\$5,000	\$3,000–\$6,000
Carpentry	\$30,000	\$36,000	\$42,000	\$50,000
Certification				
CSA certification	\$5,000	\$5,000	\$5,000	\$5,000
Total square feet	170–220 sf	296 sf	372 sf	500 sf
Cost per square foot (max)	\$363.64–\$470.59/sf	\$327.71/sf	\$317.20/sf	\$284/sf
TOTAL	\$72,000–\$80,000	\$86,000–\$97,000	\$107,000–\$118,000	\$127,000–\$142,000
Monthly rent	\$500+	\$800–\$1,200	\$1,200+	\$1,200+

Modular tiny houses		Shipping container tiny house	
ITEM	SIZE & TRAILER DIMENSION		
	200–300 square feet (M studio)	400–500 square feet (M1 ¹⁶ ; 1 bed/bath)	400–500 square feet (H03 ¹⁷ ; 1 bed/bath)
Construction			
Build of home, including labour (excludes appliances)	\$110,000	\$145,000	\$195,000
Setup			
Foundation & utilities	20–30% MSRP ¹⁸	20–30% MSRP	20–30% MSRP
Shipping	\$3,000	\$6,000	\$5,600
On-site installation	\$5,000	\$6,000	\$16,500
Total square feet	273	420	528
TOTAL	\$118,000 + 20–30% MSRP	\$157,000 + 20–30% MSRP	\$217,000 + 20–30% MSRP
Monthly rent	Varies	Varies	Varies

¹⁶ Modular Homes Canada. Homobobo (M1 Series); homobobo.com/ca/m1

¹⁷ Modular Homes Canada. Homobobo (H03 Series); homobobo.com/ca/ho3

¹⁸ Manufacturer Suggested Retail Price

Assumptions for Table 2

ASSUMPTIONS: MOVEABLE TINY HOUSE

- › Professionally built with new appliances and to CSA standards
- › Batt insulation: R12 walls and R18 floors and ceiling
- › Batt and rigid foam board insulation: R12 walls and R26 floor and ceiling
- › Insulation: R22 walls and R40+ ceiling

ASSUMPTIONS: MODULAR AND CONTAINER TINY HOMES

- › Shipping estimate is from Edmonton to Vancouver
- › Foundation is a concrete perimeter with a three-foot crawl space; foundation and utility costs factored at 20-30% MSRP which are not included in the total cost. (Note: Foundation and utility costs have been combined as one figure, given they are both impacted by the same site-specific variables: location, season and workforce availability.)
- › On-site installation includes cranework and labour
- › Modular units are BC Building Code compliant
- › Certification cost to consumer is built into the total cost
- › Total cost excludes permit fees and sitework (landscaping), both of which are city and site-specific

ACTUAL COSTS AND FINANCIAL CONSIDERATIONS

The tiny homes user satisfaction survey (see page 27 and Appendix A) conducted for this report showed that 78% of tiny home residents owned their unit and bought it for under \$100,000. Whether this is affordable is up for debate, especially when those who purchased their houses did so without a mortgage. In fact, 43% financed their purchase using their personal savings, 28% through a personal loan or line of credit and 14% via a private lender. This begs the question, who can afford to go tiny?

Aside from the cost of a tiny home, tenure of land is an additional consideration. Although owning property is an option for tiny homeowners, none of the survey respondents owned the land on which their tiny house resided. Their land was rented, they had permission to use it for free (or in exchange for labour as part of a tiny house community for those experiencing homelessness), or they were parked illegally. Renters are paying an average of \$400 per month to keep their tiny homes on these properties. Those living as part of a homeless housing project pay a nominal amount, or no cost at all.

Tiny homes may be less expensive to build than conventional single-family dwellings or other housing types. However, tenure and financing remain hurdles preventing tiny houses from becoming the affordable option they have the potential to be.

4 | Opportunities



Open viewing of a tiny house at go, go TINY. Image credit: BC Tiny House Collective

Tiny homes offer a wide range of opportunities with two main benefits: an expedited construction process in comparison to the construction of traditional single-family homes; and the option of incorporating green practices and technologies.

Quick to build

While a tiny house has the same features of a larger home, its size allows for quicker build times. This has sparked great interest among emergency response housing providers, including homeless advocates. On average, a small modular or container home can be constructed in days or weeks, while a moveable tiny house can be built in less than a month, depending on its design, features, and work crew.

Go small, go green

Tiny houses open the door to a greater conversation on building practices and the environment.

There are several reasons why people choose to live smaller. For some, the primary motivation is to live autonomously with freedom from financial restrictions, and the physical ability to live wherever they can park (especially if the unit is on wheels). For others, embracing a minimalist lifestyle is a driver for going tiny. This has less to do with sustainability and more to do with the desire for self-actualization and the “attractiveness of personal choice and [liberation]”¹⁹.

¹⁹ Mangold, Severin, and Toralf Zschau. “In Search of the ‘Good Life’: The Appeal of the Tiny House Lifestyle in the USA.” *Soc. Sci.*, Vol 8, Issue 26 (2019), doi:10.3390/socsci8010026



A recent article on living tiny by The New York Times:
[nytimes.com/2019/09/03/realestate/the-enduring-appeal-of-micro-living.html](https://www.nytimes.com/2019/09/03/realestate/the-enduring-appeal-of-micro-living.html)

There is great merit in reducing material consumption. However, not all tiny homes are energy- and water-efficient, or have a reduced carbon footprint. Traditional housing models, such as multi-unit buildings, townhouses and duplexes—are arguably more efficient housing options.

Detached tiny homes do not have the advantage of shared walls, which reduce the amount of energy needed to heat and cool buildings, nor can they accommodate as many units per lot. Tiny homes, even in clustered/community developments in many cases require more land per unit than multi-unit buildings. Additionally, the illegal status of tiny homes in most B.C. communities, encourages many residents to park in remote areas. This requires longer commutes to access everyday amenities and increases their carbon footprint. Many tiny home dwellers have incorporated small-scale innovative practices into their structures, such as building 3D printed houses, and using composting toilets, solar panels and other renewable energy systems, rainwater harvesting systems and more.

“My partner and I live in very close quarters and have learned to live in relative harmony. We both take responsibility for maintaining the house and enjoy sharing in those tasks and troubleshooting through the process. It has enabled us to live with very little unnecessary material and it’s a great excuse to not accept junk that people want to give you, like token gifts. Keeps our priorities straight. The big impact has been the freedom of being debt-free which this has enabled us to be even (remain) in Metro Vancouver, so we don’t have big money stress and we can build a future. Gives us more flexibility to make big changes (quit jobs, go back to school, start a family) with much less financial pressure. We are living our values and that feels really good — more sustainable, less about things, being really engaged with our waste stream. Living in something we built ourselves and knowing the skills we acquired along the way is exceptionally satisfying.”

—Anonymous, user satisfaction survey respondent, 2019

A SUSTAINABLE TINY HOUSE IN ACTION



Exterior render of the Northern Nomad tiny house. Image credit: Brigitte Martins

In 2017, students from Carleton University's Faculty of Engineering and Design, and the Azrieli School began a moveable tiny house construction project called the **Northern Nomad**²⁰. Through simulation and data collection, its goal was to investigate the potential of carbon positive living within a small footprint, primarily by using innovative technologies, smart house features and examining the envelope's embodied energy²¹. The unit was built over two phases: 1) design and build, and 2) instrumentation (in progress as of 2019).

It was designed to be net zero, meaning it will generate enough renewable energy annually to meet or even exceed its energy needs. Net zero is accomplished by using 14 roof-mounted solar panels for energy collection, lead-acid batteries for storage, and a heat pump to provide heating and cooling to interior spaces. Pure water is harvested from outdoor air, using a humidifier with a two-stage filtration. The system uses ultraviolet radiation and remineralization (atmospheric water generator storage), and then stores treated water in five rainwater tanks for future use.

²⁰ Burke, Tyrone. "Tiny House Opens Doors". *Carleton University*; newsroom.carleton.ca/story/tiny-house-northern-nomad

²¹ Embodied energy refers to the sum impact of all greenhouse gas emissions attributed to a material during its life cycle, including manufacturing, transport and product delivery

The house is 220 square feet (7 × 26 × 13.5 feet) and includes a loft bed, living area, full kitchen, laundry facilities, and a bathroom with a shower and composting toilet. The home is also automated with a thermostat, lighting and heat pump, which are all controlled by voice command or smartphone. The Northern Nomad is built to Part 9 of the Ontario Building Code and all structural, electrical, plumbing and carpentry work was inspected by Carleton University professors and a certified electrician.

While the project delivered on its sustainable objectives, it has plenty of lessons to share:

- › The intention was to have the house equipped with a Tesla lithium-ion battery, but the added cost of requiring third-party certification forced a change of plans.
- › There was also the issue of affordability. With the build closing in at \$100,000, how accessible is a sustainable tiny home? Carleton University is continuing its research to address this question and others. Their top priorities are to determine if this model can be scaled, how to dispatch energy based on need, as well as exploring future uses such as mobile medical monitoring units.

“It is important to think about how our construction practices, design tendencies and daily lifestyles affect the environment, and this project [Northern Nomad] embodies this consciousness in many ways. I don’t think it is necessary for everyone to live in a tiny house in order to see positive change—nor would I encourage that—though, I do think that they help us challenge what we think we really need in order to live a healthy and fulfilling life.”

—*Brigitte Martins, Designer of Northern Nomad Tiny House, Carleton University*

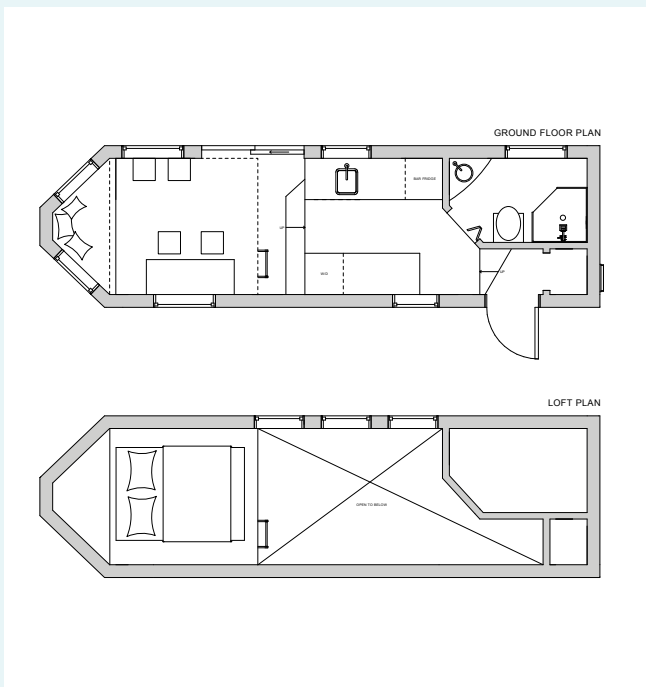

The Northern Nomad floor plans (left) and solar panels mounted on the unit’s roof (right). Image credits: Brigitte Martins

Anecdotal findings show that individuals are increasingly adopting environmentally conscious behaviours that promise health, safety and sustainability benefits. Off-grid living is an alternative for people who want to reduce their carbon footprint; a common practice in tiny homes. In fact, finding alternative energy sources (including solar panels and batteries) promotes self-reliance and the development of personal skills. Also, when tiny houses are sited in intentional communities, the option for car sharing and carpooling with fellow community members helps reduce the carbon footprint of rural living, further demonstrating their positive environmental impact.

Innovative technologies

While small in size, the form can showcase various sustainable products, systems, and technologies that make up for its subsequent heat loss. These include solar panels, composting or incinerating toilets, rainwater harvesting, filtration and irrigation; and grey- and blackwater management systems, building material reuse (if non-structural) and alternative foundations. Foundations may include concrete piers and helical screw piles, or others. Here are a few innovative technologies in greater detail:

- ▶ **Alternative energy:** There are many great examples of tiny houses which incorporate alternative energy systems into their design. The market has made great advances by introducing innovative technologies to reduce environmental impacts and decrease operating costs; solar, renewable energy is one example.

Solar energy is a clean and sustainable resource that can be used to heat and power a home using solar photovoltaic (PV) systems. The solar panel generates power by converting sunlight to direct current electricity. Inverters are then used to convert the direct current electricity to alternating current electricity to be used in the home.

There are two main types of solar PV systems: 1) grid-tied systems, which feed alternating current electricity directly to the local grid, 2) off-grid systems, which store direct current electricity in batteries for later use.

In remote locations that lack access to the electricity grid, off-grid solar panel systems can be a good alternative and investment. However, for B.C. homeowners connected to the BC Hydro electrical system, it would take at least 20 years to see a return on their investment given today's average electricity rates.

It is important to note that any grid-tied systems require complex electrical connections and must be approved by BC Hydro before installation to ensure safe and effective operation.²²

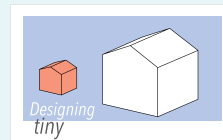

In 2018, the BC Tiny House Collective produced a tiny house design lookbook called

Designing tiny. It contains expert insight on how to manage greywater, as well as urine and solid waste from a tiny house unit or community village²³.



*Render of urine collection and sterilization tanks.
Image credit: BC Tiny House Collective*

²² BC Hydro, "Solar Power & Heating for Your Home" [bchydro.com/powersmart/residential/building-and-renovating/switch-to-solar-energy.html](https://www.bchydro.com/powersmart/residential/building-and-renovating/switch-to-solar-energy.html)

²³ Designing tiny; [bctinyhousecollective.com](https://www.bctinyhousecollective.com)

- › **Composting toilets:** As with many modern-day conveniences, conventional toilets have disconnected users from where waste goes and how it is processed. How do you manage solid waste when your toilet system is not connected to municipal lines? With the most basic of composting toilets, human excrement remains in the basin, and needs to be covered with some form of sawdust or peat moss to mask the odour and assist with decomposition.²⁴ More complex models separate urine and feces, and can also include vermicomposting (decomposition using worms), for a more sustainable process and useful end-product. Composting toilets (in all their iterations) support an off-grid lifestyle and are highly efficient in terms of water use and in converting waste. That said, a composting toilet must be able to perform three essential processes: 1) compost the waste and toilet paper quickly and without odour, 2) evaporate the liquid, and 3) ensure the finished compost is safe and easy to handle.²⁵
- › **Biogas digesters:** Since 2016, a couple living in Australia documented their tiny experiences through the blog *Living Tiny and Green*²⁶. While their solar panels do not meet the energy demands of their moveable tiny house, they have opted to install a biogas digester for cooking. The digester works like a cow's stomach, breaking down organic waste into biogas in an oxygen-free environment using water. In addition to providing methane and carbon dioxide, the excess water is nutrient-rich and can be used as a fertilizer.



Biogas digester. Image credit: Living Tiny and Green

Note, these systems are not allowed in most cities, on Indigenous land or in regional districts; and if allowed, are limited by bylaws. Also, where tiny houses are permitted, they are typically required to be connected to municipal utilities rather than relying on off-grid technologies. Additional work is required to further the progress in this area and to encourage sustainable options for tiny homes. See Section 6, Tiny homes, Codes and Standards for more information.

²⁴ Charlie Kilman, "Small House, Big Impact: The Effect of Tiny Houses on Community and Environment". Undergraduate Journal of Humanistic Studies, Winter, Vol 2 (2016)

²⁵ Harrington, Nancy. "How Composting Toilets Work"; let'sgogreen.com

²⁶ Living Tiny and Green; livingtinyandgreen.com

5 | Challenges



Public open house on City of Victoria's housing strategy. Image credit: City of Victoria

In August 2016, the BC Tiny House Collective held a multi-stakeholder workshop. In attendance were city councilors, urban planners, designers, architects, non-profits, developers, builders, students and other key players from across the Metro Vancouver Area. The purpose was to bring the right people together to identify the challenges around tiny house legalization. Through this conversation, three main barriers were identified: political, financial and cultural.²⁷

²⁷ "Meeting Minutes". BC Tiny House Collective; bctinyhousecollective.com/wp-content/uploads/2019/09/BC-Tiny-House-Collective_August-2016-stakeholder-meeting-minutes.pdf

Political

Local governments, especially those in high-cost land and housing areas, are grappling with how to zone tiny houses into their development and community plans. This however, complicates a few things—building codes and safety standards, minimum square footage, homeownership and tenure models and, servicing. These are all barriers from the perspective of planning, engineering and building departments. While most municipalities already allow prefab and container units, there is a concern that introducing moveable tiny houses may open the door to recreational vehicles and mobile homes.

Industry is taking steps to introduce standards that are compliant at the municipal, provincial and federal levels. Some cities or regional districts are overlooking codes altogether, drawing on development and servicing plans from trailer parks, writing ordinances or issuing Temporary Use Permit to include tiny houses as a viable form of affordable housing. Local governments’ hands are tied until decision-makers at all levels take steps to amend small housing sub-sections within provincial building codes, and certified bodies create tiny house-specific standards. Section 6 of this report explores this in more detail.

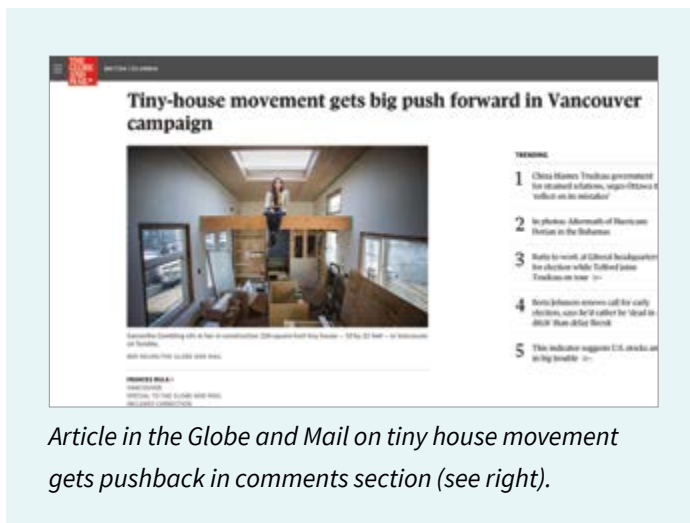

Article in the Globe and Mail on tiny house movement gets pushback in comments section (see right).

Financial

Tiny houses are still very unique in the eyes of financiers and insurers. As such, there are a lot of unknowns:

- › How are people currently financing the purchase of their tiny homes?
- › What do lenders need to issue loans or mortgages for moveable units?
- › What risks are associated with private lending?
- › How will these homes devalue over time?
- › Will the use of tiny houses as accessory dwelling units (ADU) impact land values?

More research and industry champions are needed to answer these questions. Investigating processes related to other forms, such as RVs and float homes, in terms of financing and insurance may hold the keys to unlocking the tiny market. See Section 7 of this report for more on financing tiny homes.

“Tiny houses = ‘artisanal trailer park.’”

—G. Rumble²⁸

²⁸ Bula, Frances. “Tiny-house Movement Gets Big Push Forward in Vancouver Campaign”. *The Globe and Mail*; theglobeandmail.com/news/british-columbia/tiny-house-movement-gets-big-push-forward-in-vancouver-campaign/article33630429/



A prevailing challenge that trailer parks face is the stigma of poverty, and that tiny houses in a community-setting are nothing more than an artisanal trailer park. Image credit: tinyhomebuilders.com (top)

Cultural

There is definite pushback from citizens who see tiny houses as a cause of slums or deteriorating land values, or compare them to an over-glorified RV park. Why is there a tendency to vilify mobile home communities that attempt to create a sense of place and provide affordable housing? There are opportunities for the media and others to highlight the benefits of the tiny house form beyond being trendy and for millennials.

“Trailer parks are marked by the stigma of poverty while tiny houses seem to embody ingenuity, sustainability, and minimalism.”²⁹

The [Tiny House Advocates of Vancouver Island \(THAVI\)](#),³⁰ a grassroots advocacy group working to introduce tiny houses into city plans, conducted a landowner survey in 2018. The goal was to assess whether property owners would accept moveable tiny houses in their neighbourhood and/or rent space on their property to park the house as an ADU.

THAVI received 85 responses from landowners in Victoria and Saanich; 96.5 percent said they would welcome a “well-built attractive moveable tiny house” into their neighbourhood. Equally, 88.24 percent were in favour of having a moveable tiny house on their property, for their own use or a family member. Common concerns included parking, connection to municipal services (including waste management), as well as landlord rights, noise from tenants, fears of increased crime and blending into the neighbourhood. That said, 93.9 percent of those polled said they would accept moveable tiny homes in their community if their concerns were met.

THAVI received 85 responses from landowners in Victoria and Saanich; 96.5% said they would welcome a “well-built attractive moveable tiny house” into their neighbourhood. Equally, 88.2% were in favour of having a moveable tiny house on their property, be it for their own use or a family member.

Also, the BC Tiny House Collective’s *Designing tiny*³¹ lookbook included five tiny house examples placed as laneway houses on single-family lots in the City of Vancouver. These units were constructed locally, on lots whose owners were open to having similar models as ADUs in their backyards. This demonstrates that while some are against tiny homes and the movement, many are in favour of incorporating them into existing neighbourhoods; either as an affordable rental option and as a means of generating additional income for property owners. The case study section of this report highlights how some groups have overcome the pushback on tiny homes to create intentional and successful communities (see page 69).



Spreads from the *Designing tiny*³¹ lookbook

²⁹ Brown, Emily. “Overcoming the Barriers to Micro-Housing: Tiny Houses, Big Potential.” Dissertation, *University of Oregon, Department of Planning, Public Policy and Management*, 2016; hdl.handle.net/1794/19948

³⁰ Tiny House Advocates of Vancouver Island (THAVI); thavi.ca/

³¹ *Designing tiny*; bctinyhousecollective.com/wp-content/uploads/2019/09/BCTHC_Designing-tiny_City-of-Vancouver-design-lookbook.pdf

Perception and impacts on quality of life

While this sub-section did not stem from the BCTHC workshop, it examines all three barriers—political, financial and cultural—and warrants further discussion.

Many advocate that tiny homes should be considered a viable form to address the housing needs of the “missing middle.” After all, it’s a choice for those who want to live smaller. To some extent, the form has even been culturally normalized through TV shows, YouTube videos, personal blogs, and advocate websites. Others are quick to say that tiny houses are far from homes. There is more than one solution to address the housing shortage, and tiny is not for everyone.

City planning departments are now taking part in the conversation. Some have gone so far as to include the form in their official community plans, while many are debating allowable home size and its impact on liveability. Others are questioning whether tiny homes have a place in our communities at all.

The BC Tiny House Collective, in partnership with nursing students at Vancouver Community College, conducted a literature review in 2016 to determine whether there was any correlation between tiny living and impacts on determinants of health. They looked at the impact on income, social connections and support, employment and working conditions, physical environments, child development, access to health services, colonization on Indigenous people, and the immigration process.

Building off this work, Gambling and Laliberte (2019) reviewed available anecdotal and research on the health impacts of tiny house living. They cited many possible benefits, including strengthening social connections and mutual aid, engagement in community decision-making processes, and personal empowerment.



Illustration of the missing middle. Image credit: Small Housing BC

Tiny homes allow more autonomy from government systems for Indigenous people, and greater financial freedom (and associated reduction in stress). Tiny homes offer greater independence, security and self-reliance.³²

Due to the current legalization status of tiny homes, many owners are pushed outside of city limits, which can exacerbate social isolation, impede a sense of community and eventually result in a reduction of well-being and quality of life. As one tiny homeowner states, “I would have to be in a more central spot. Right now it’s too far from amenities—I miss biking and walking places. I need to drive everywhere. If it were legal in a city, I could live right in the city centre in a backyard and would be able to walk everywhere.”

—Anonymous tiny homeowner, user satisfaction survey respondent, 2019

³² Gambling, Samantha, & Laliberte, Shari. “Tiny Homes: A Good Option for the Body, Mind and Spirit.” *Visions* Vol. 14, no. 4 (2019).

www.heretohelp.bc.ca/sites/default/files/visions-rethinking-housing-vol14.pdf

This aside, education and tours (of both tiny houses and manufacturing facilities) are a big component to building greater public and political will, while also expanding positive perceptions of the form. This requires meaningful outreach and dynamic partnerships between industry, government and local residents.

There is no doubt that we're at a crossroad and charting new territory. Tiny living requires bold re-thinking.



Example of a tiny home

6 | Tiny homes, codes and standards



The Northern Nomad under construction. For more on this project, see page 35. Image credit: Brigitte Martins

Building codes and standards are the primary tools to protect health, safety and community welfare, while encouraging energy efficiency as it pertains to homes. This section explores what extent tiny homes comply with government and industry requirements when it comes to construction, plumbing, fire codes and standards. This analysis is focused on British Columbia. It does not extend to other provincial codes and regulations, with the exception of the National Building Code of Canada (NBC), and Canadian Standards Association (CSA) Group.

So how do moveable, prefabricated and container tiny homes fit into the code landscape?

This depends heavily on how the unit is manufactured and used. This section speaks to standards, as well as the components and design features most commonly found in

tiny houses that are non-compliant. It highlights amendments made to regulations in the United States and proposed changes to Canada's National Building Code, with the recommendation to also amend the British Columbia Building Code (BCBC).

The British Columbia Building Code (BCBC) is a provincial regulation that governs new construction, building alterations, repairs and demolition. It provides a set of minimum requirements for safety, health, accessibility, fire, structural and component protection of a building. It also offers guidance on energy and water efficiency. Part 9 of the BCBC applies to small residential buildings that are three storeys or less in height, not larger than 600 m² and used for residential, commercial, or medium-to-low hazard industrial purposes.

The BCBC is based on the National Building Code—a baseline for all provincial codes—and is applied throughout British Columbia with the exception of some federal, First Nations, and the City of Vancouver lands; the latter has its own code called the Vancouver Building By-law (VBBL). Municipalities throughout B.C. are mandated by the Building Act to conform

with the BCBC, however when a provincial building regulation does not regulate a matter, local governments may regulate them if they have legislative authority to do so.³³ The last amendment to the BCBC was in 2018; the next one is due in 2023.



Tiny house in construction. Image credit: Tiny House Talk

SMALL IN VANCOUVER

This Vancouver laneway home—two-storeys tall and wood-framed—is placed on a permanent concrete foundation and designed to meet the Vancouver Building By-law. The home is 351 square feet (522 sf with a conditioned garage).³⁴

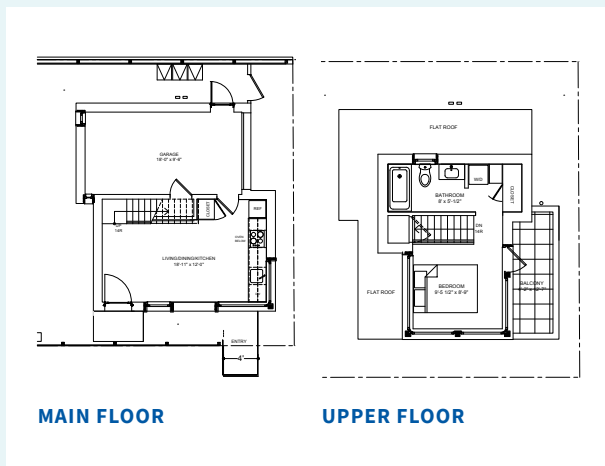

Laneway house on West 22nd Avenue, City of Vancouver. Image credit: Lanefab Design/Build

THE NATIONAL BUILDING CODE

The National Building Code sets the framework from which the provinces, territories and municipalities can build, and is the standard countrywide that product manufacturers and contractors must follow when it comes to design and construction.³⁵ This code allows for consistency in product design and use across Canada, and is comprised of three parts:

1. The National Building Code of Canada, which addresses the design and construction of new buildings and the substantial renovation of existing buildings
2. The National Fire Code of Canada, which outlines the minimum requirements for fire safety in terms of fire prevention and protection
3. The National Plumbing Code of Canada, which outlines how plumbing systems should be designed and installed

³³ See page 5 of “B1: What Local Governments Need to Know about the Building Act”; www2.gov.bc.ca/assets/gov/farming-natural-resources-and-industry/construction-industry/building-codes-and-standards/guides/baguide_sectionb1_june2016.pdf

³⁴ Davidson, Bryn. “Lanefab Design/Build.” *Lanefab Design/Build*; lanefab.com/

³⁵ Government of Canada. “How the National Codes are Developed.” *National Research Council Canada*; nrc.canada.ca/en/certifications-evaluations-standards/codes-canada/codes-development-process/how-national-codes-are-developed

FIGURE 1. TINY HOMES TODAY: CODES AND STANDARDS THAT CURRENTLY EXIST AND AREAS TO FOCUS ON WITH FUTURE CODES AND STANDARDS

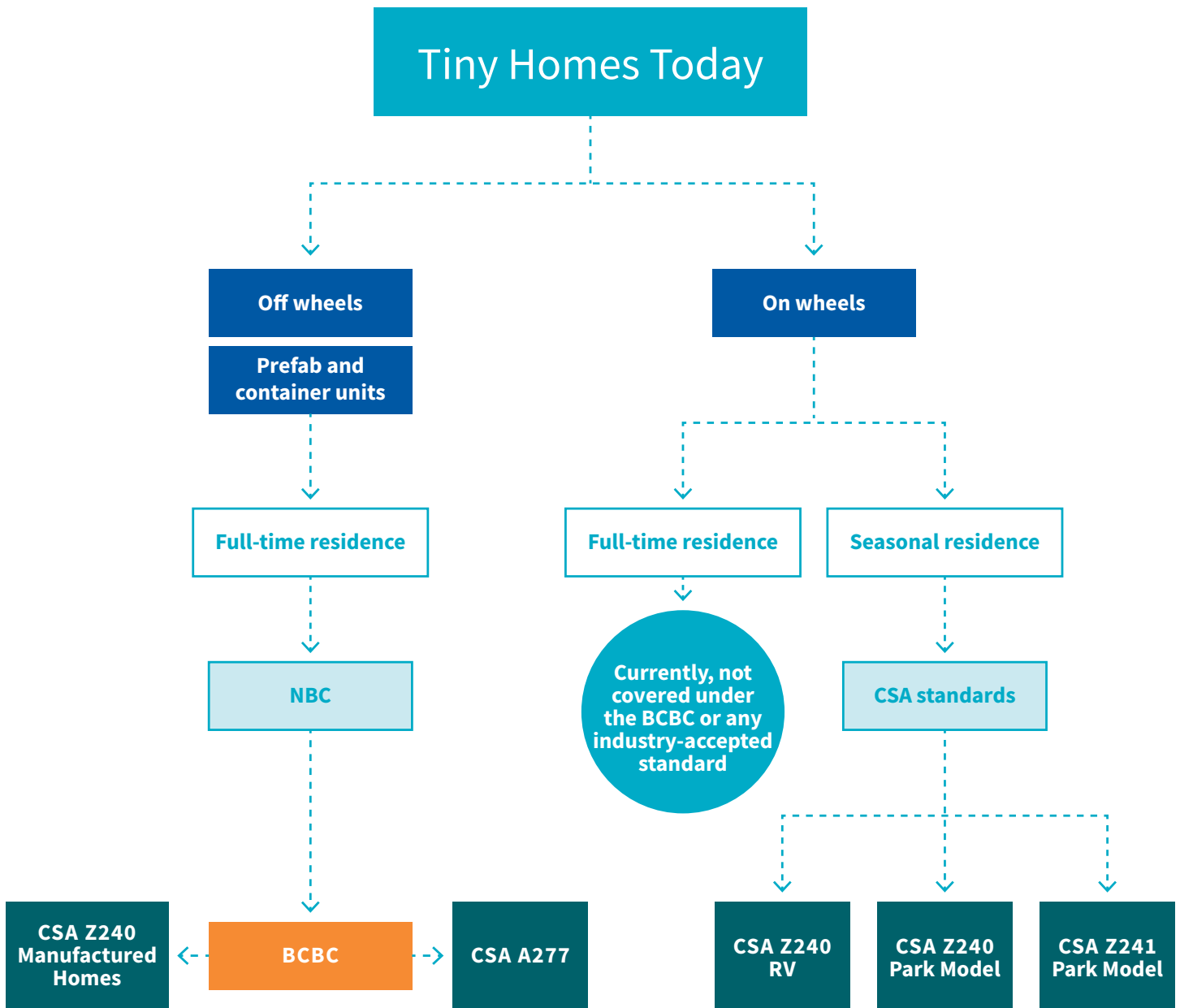

An overview: BC Building Code

The BC Building Code (BCBC) delves into three parts: building, fire and plumbing. Here is how these sections speak to tiny house construction in more detail:

1. Building: According to the Building and Safety Standards Branch within the Office of Housing and Construction Standards, the BC Building Code³⁶ does not prohibit tiny houses. As per the BCBC, a tiny house is required to follow Part 9 requirements of the building code which apply to buildings that are three storeys or less, and do not exceed 600 m². The BCBC does not specify a minimum size for any room in a house, bedroom or otherwise. The challenges for tiny homes generally align with the following requirements:

- › Foundation (concrete, wood or unit masonry foundation walls), or floor-on-grade (wood on concrete)³⁷
- › Electricity and plumbing (permanent hookups)
- › Smoke alarm (and CO alarm if the home has fuel-burning appliances)
- › Entrance/exit door widths (810 mm by 1980 mm)
- › Toilet, sink and shower/bathtub
- › Egress window or door to the exterior from the sleeping area

Equally, it must meet:

- › Energy efficiency Step Code requirements for EnerGuide (thermal envelope performance and air tightness in higher steps)³⁸
- › Ceiling height minimums for living spaces (living, dining, kitchen, bedroom and bathroom) is 2.1 m

2. Fire. Occupant safety is a concern with any structure that is constructed, and safety during a fire is no exception. Homes are designed with burn times, fire barriers, fire retardant materials and means of egress in mind. As units become smaller, more effort is required to ensure that safety during a fire is maintained. As such, designs for small homes must account for proper egress to and from a home from all spaces—a challenge when spaces, hallways, doors and windows become smaller. Other hazards include sleeping lofts and egress access in the event of an emergency. As well, the clearances around gas, propane and electric cooktops, can limit the amount of cabinetry allowed directly above and beside appliances.³⁹

Codes and tiny houses in the US

Although the BCBC and National Building Code do not permit sleeping lofts with ship ladder access, the United States does through Appendix Q Tiny Houses in the 2018 International Residential Code (IRC). This amendment has incorporated several tiny home components and design features into the code, including sleeping lofts, where a window built into the roof is an acceptable means of emergency egress. The IRC provides a blanket standard for tiny homes but does not guarantee state and municipal adherence. As of July 2019, the following states approved Appendix Q: Idaho, Oregon, Georgia, Colorado (Garfield County only) and Maine.⁴⁰ To view the live IRC proceedings on Appendix Q Tiny Houses, see the Tiny House Expedition's film *Living Tiny Legally Part 2*:

youtube.com/watch?v=3qDG8X83auU



³⁶ See BCBC part 1 Section 1.3.3.3 Application of Part 9

³⁷ See BCBC 9.15 Footings and Foundations, and 9.16 Floors-on-grade

³⁸ See 2018 BCBC Section 9.36.6 Energy Step Code

³⁹ See BCBC 9.10.22 Clearances reference Standards (CSA electrical code CC22.1 and CSA B149.1 Natural gas and propane installation code) providing required clearances around stove

⁴⁰ "Tiny House Appendix Q". *Tiny House Build*; tinyhousebuild.com/code/



Bathroom of the Eclipse tiny house on wheels.

Image credit: Tiny Healthy Homes

“A number of states, including California, have approved the new IRC code, inclusive of Appendix Q. Appendix Q does not apply to moveable tiny homes but does apply to factory-built houses (FBH). Thus, one could have a licensed/certified shop build a tiny FBH and take it to a site for use as a home or accessory dwelling unit. (Note: A FBH will have to be placed on a foundation approved by local building officials.)

It’s likely that you will see a number of mobile tiny house (MTH) builders now offering basically the same unit as both a MTH or FBH. Since most buyers of MTH aren’t using them for travel, but for housing in a semi-permanent site for several years, they can choose the FBH option and then in several years sell it to move to another location.”

—Daniel Fitzpatrick, Director of Government Relations and Advocacy, American Tiny House Association

3. Plumbing. The proper treatment and handling of water, especially grey (water waste through drainage) and blackwater (sewage), is important to protect human health and environmental safety. Also preventing the release of chemicals and biological materials into the environment is a requirement of most municipalities. How buildings handle or contain their liquid waste is governed by the municipality in which the structure resides. These requirements govern how a tiny home is designed and dictate if the structure is permitted to have holding tanks, or if it is required to connect to a permanent handling system, such as a septic tank or sewer system. Additionally, if all plumbing connections are compliant with the BC Plumbing Code, then they are not considered to be temporary. Temporary connections are not permitted unless the building complies with CSA Z240 RV (see below). The BCBC states that every dwelling unit shall be supplied with potable water. Where piped water supply is available, dwelling units are required to have a kitchen sink, lavatory, bathtub or shower and water closet. The unit must also be supplied with hot water (BCBC 9.31.3 and 4).

CSA standards

The Canadian Standards Association (CSA) Group develops and administers standards that apply across industries and relate to construction, infrastructure, electrical, public safety, transportation and the environment. Its goal is to ensure built products and offered services are measured and evaluated against an industry-standard, to ensure quality and safety.

CSA has three standards (and two subsections) that apply to tiny homes—whether they are constructed on wheels, wood- framed or using prefabricated design or container units—CSA A277, Z240 and Z241. As such, these housing types are viewed as a product that can be built in a factory, scaled and comply to a minimum standard. Inspections take place at the factory during construction to ensure standards are met. This benefits the manufacturer, as well as various end-users, including the homeowner and municipalities. The standards ensure the products are certified and demonstrate compliance, while ensuring the house is built and verified to specific guidelines.

It should be noted that CSA is a standard and not a building code as stated by BCBC (A1.1.1.1.3.). Here are five CSA standards in more detail:

I. CSA A277: PREFABRICATED BUILDINGS AND MODULES

Factory-constructed homes can be certified in accordance with CSA A277 Procedure for Certification of Prefabricated Buildings, Modules and Panels. In October 2015, the provincial government released an information bulletin from the Building and Safety Standards Branch (BSSB) which reads as follows:

“The same requirements exist between a site-build and a factory-build, however, factory builds make it difficult to determine their level of compliance with local codes because they arrive to site as a completed unit. CSA Standard CAN/CSA-A277, ‘Procedure for certification of prefabricated buildings,’ was developed to address this problem. It describes a procedure whereby an independent certification agency (CSA) can review the quality control procedures of a factory and make periodic, unannounced inspections of its products and thus, through suitable labeling, provide assurance to authorities at the final site that those components which cannot be inspected on site comply with the code indicated on the label.”⁴¹

The 2018 BC Building Code includes an appendix to clarify how conformance with the CSA A277 standard is to take place for factory-built buildings. As well, the 2018 BCBC provides clarification that factory-built housing is not exempt from the code and specifically that “siting” of factory-built housing must comply with spatial separations.

At approximately 220 square feet, the Rufous 20 model from Hummingbird Micro Homes⁴² is a compact home that meets the requirements of everyday living and complies with the CSA A277 standard.

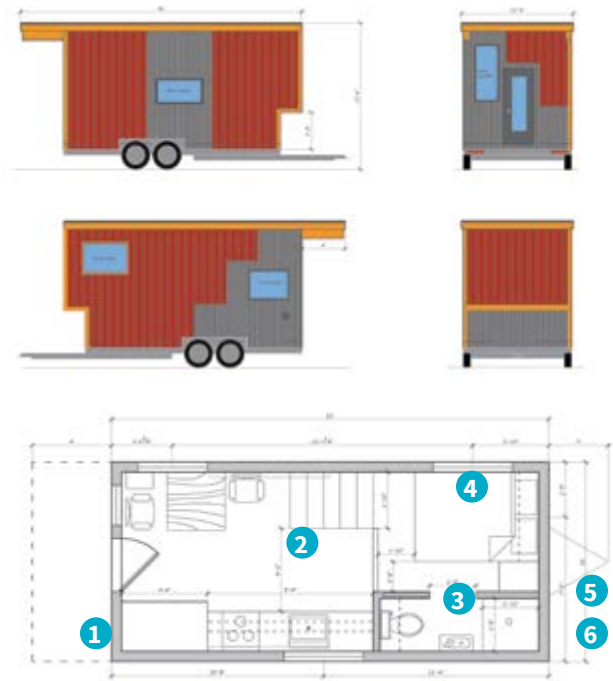

HUMMINGBIRD MICRO HOMES 20-FOOT RUFIOUS MODEL

1. Insulation levels, R24 walls, R34 roof, R28 in the floor
2. Full size stairs
3. Seven-foot floor to ceiling (no loft)
4. Secondary egress (window)
5. Designed to connect with seismically permanent landing
6. Built on permanent foundation

⁴¹ Government of British Columbia. “Determining Compliance of A277-Certified Buildings.” *Information Bulletin Building Safety Standards Branch*; www2.gov.bc.ca/assets/gov/farming-natural-resources-and-industry/construction-industry/building-codes-and-standards/bulletins/b15-01_determining_compliance_of_a277certified_buildings.pdf

⁴² “Rufous 20.” *Hummingbird Micro Homes*; hummingbirdmicrohomes.com

II. CSA Z240

A. CSA Z240: Manufactured homes



Grantham house by Click Modular Homes

As defined by CSA, manufactured homes (MH) are transportable, single- or multiple-section, one-story dwellings ready for occupancy on completion of set-up in accordance with the “manufacturer’s instructions” (Technical Safety BC).

This style of home arrives to site in finished or partially assembled pieces which are then installed onto permanent foundations. Once fully assembled, manufactured homes are not intended to leave the site and are considered a permanent dwelling. In British Columbia, these homes are built to BC Building Code standards. Building inspectors must ensure that the homes are built to provincial or local building code or that the manufacturing company has been certified to produce CSA Z240 MH homes.

Dwelling unit defined

The British Columbia Building Code defines a *dwelling unit* as a “suite operated as a housekeeping unit, used or intended to be used by one or more persons and usually containing cooking, eating, living, sleeping and sanitary facilities.” Permanence, as it relates to a dwelling, means it can be used for full-time living.

B. CSA Z240: Recreational vehicles



A Class A motorhome. Image credit: Claygate, Wikipedia

The recreational vehicle standard falls under the umbrella of CSA Z240 for prefabricated structures and can be broken down into two subsections which are motorized and towable models. Included in this category are motor homes, travel trailers, fifth wheels, truck campers, tent trailers and park model trailers. These models are designed for seasonal use in a singular location and are not considered full-time residences. Tiny homes built to this standard are permitted for temporary-use only.

C. CSA Z240: Park model (8-foot wide)



Sonora tiny house by Tiny Healthy Homes

Units built to this standard are usually towed by larger tow vehicles. Because there are specific limitations to the size and weight of these units, they do not require any special permit to be towed on highways in Canada. Homes built to this standard cannot be used as permanent dwellings.

III. CSA Z241: PARK MODEL (10 TO 16-FEET WIDE)

Like the CSA Z240 Park model, Z241 allows for a structure to be towed from location to location and parked wherever permitted. Unlike the 8-foot-wide models, units built to this specification require specialized tow vehicles and permits to be transported on Canadian highways. Homes built to this standard cannot be used as permanent dwellings.

For more information on American standards as they relate to tiny homes on wheels, RVs or park models, see the American National Standards Institute (ANSI) 119.2 and 119.5 requirements, or the National Fire Protection Association (NFPA) 1192 Standard.



Designed by Tiny Healthy Homes, the Z241, CSA-approved Cascadia is designed for family living with closed rooms for privacy and comfort



Interior of Cascadia, Tiny Healthy Homes

Tiny house features and code compliance

Here is an overview of the main design features of moveable and tiny homes that may not be compliant across all codes and standards:

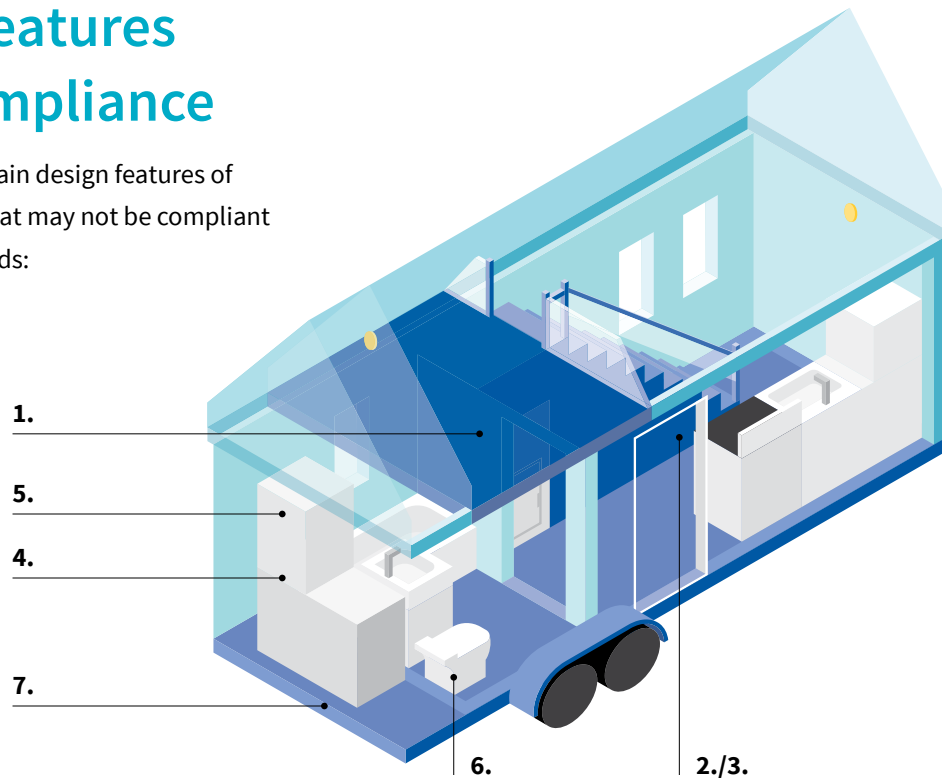

TABLE 3. TINY HOUSE FEATURES AND CODE COMPLIANCE

NO.	FEATURE	VBBL ⁴³	BCBC	NBC	CSA	IRC ⁴⁴
1	Sleeping loft	✗	✗	✗ ⁴⁷	✓	✓
2	Ship ladder	✗	✗	✗	✓	✓
3	Steep staircase access	✗	✗	✗	✓	✓
4	Greywater filtration system	✓	✓ BC Plumbing Code	✓	✓ CSA B128.3, CAN/CSA-B128.1/B128.2	✓ NSF ⁴⁵ /ANSI 350 standard ⁴⁶
5	Rainwater harvesting and filtration	✓ City of Vancouver Building Bylaw Plumbing Systems	✓ BC Plumbing Code	✓ National Plumbing Code	✓ CSA B805-18/ICC 805-2018 — Rainwater Harvesting Systems National Standard ⁴⁸	Does not specify — International Plumbing Code ⁴⁹
6	Compost toilet	✗	✗ ⁵⁰	✗	✓ Except for A277 when required to connect to municipal services, code may differ	✓
7	Chassis foundation	✗	✗	✗	✓	✓

⁴³ City of Vancouver Building By-law (VBBL)

⁴⁴ International Residential Code (IRC), as is it relates to Appendix Q Tiny Houses

⁴⁵ National Sanitation Foundation (NSF); see [nsf.org/](https://www.nsf.org/)

⁴⁶ ANSI 350 Standard; [watertechnology.com/international-plumbing-and-building-codes-adopt-standard-for-water-reuse-systems/](https://www.watertechnology.com/international-plumbing-and-building-codes-adopt-standard-for-water-reuse-systems/)

⁴⁷ Note: Sleeping lofts are permitted with the following considerations which are typically not able to be accommodated in tiny houses. National Building Code: Full ceiling height, minimum room width, sufficient guards at the edge of the loft and an emergency escape window

⁴⁸ Eco-Sense. “CSA B805-18: The Number That Catches the Rain.” *Rainwater Harvesting*; rainwaterbc.com/2018/11/10/csa-b805-18-the-number-that-catches-the-rain/

⁴⁹ Rainwater harvesting and filtration is not addressed in the IRC and is left up to local jurisdictions to specify; [epa.gov/sites/production/files/2015-11/documents/rainharvesting.pdf](https://www.epa.gov/sites/production/files/2015-11/documents/rainharvesting.pdf)

⁵⁰ BCBC 9.31.5 Sewage Disposal states dwelling units must discharge into a public sewage system or into a private sewage system (septic tank with absorption field) where a public sewage system is not available; however, composting toilets have been permitted with professional engineer sign-off

SLEEPING LOFT

According to the BC Building Code, any space used as a sleeping room (bedroom) must have a doorway directly to the outside or a window that opens up to an area no less than 0.35 m² with no dimension less than 380 mm (BCBC 9.9.10.1). However, if the suite has a sprinkler, no direct egress to the outside from the bedroom is required.

Code requirements specify bedroom ceiling heights must be no less than 2.1 m for a minimum of 5.2 m² of a bedroom space, which implies that the whole bedroom requires a height of 2.1 m (BCBC 9.5.3, Table 9.5.31). Guard rails are required by code where there is more than 600 mm difference between a walking and adjacent surface. Therefore, guard rails are required in sleeping lofts; guard heights must not be less than 900 mm high (BCBC 9.8.8.1).

SHIP LADDER/STAIRCASE

If there is a second storey, a full set of stairs and handrails are required between floors in accordance with Section 9.8 of the BCBC. The BCBC sets stair dimensions requirements for exit stairs serving a single dwelling unit as follows:

- › Stair width not less than 860 mm (9.8.2.1.)
- › Clear height over stairs is not less than 1,950 mm (9.8.2.2.)
- › Stairs shall be either straight flight or curved flight (9.8.3.1.2a)
- › Stair riser is between 125 mm and 200 mm (9.8.4.1)
- › Stair run is between 255 mm and 355 mm (9.8.4.2)
- › Stair landings as wide as the stairs (9.8.6.3)
- › Handrails between 865 mm and 1,070 mm measured from top of nosing (9.8.7.4)

This is where the main obstacle lies. Most tiny homes incorporate a sleeping loft with a ladder which is prohibited by the 2018 BC Building Code. The issue is emergency egress from a loft, and ladders are too dangerous for the elderly and small children. Both the National Building Code of Canada and the BC Building Code have no plans to permit ladder access to lofts in the future. In the updated 2018 BCBC, even spiral staircases have been removed.



Loft of the Amazing Mysterium unit at Caravan – The Tiny House Hotel, Portland, Oregon. Image credit: Jeffrey Freeman

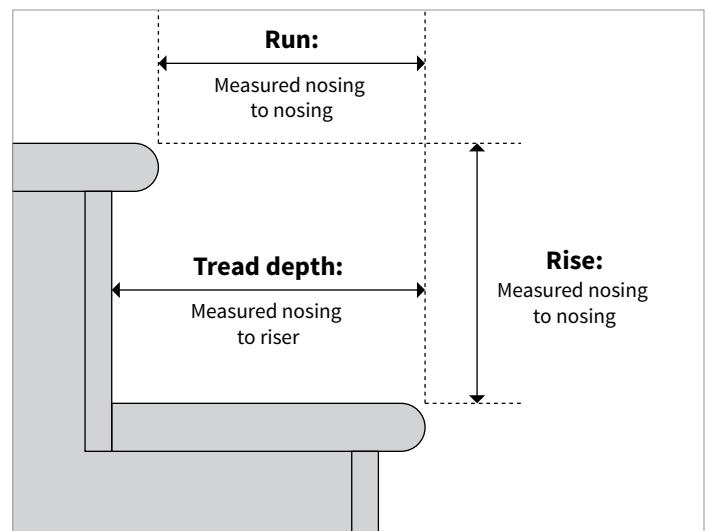
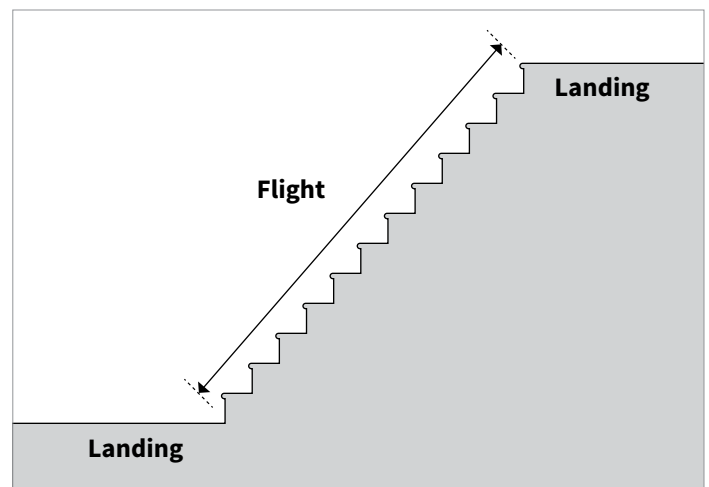

Illustrated diagram of stair flight, run and rise. See scred.ca/files/File/Community/Building/Part%209%20Part%203%20Stairs%202018%20Code%20Update.pdf

Float homes are often designed to small space standards in a way that allows for more flexibility in the staircase. Although float homes are required to be built and constructed to meet the BCBC, they have the following exemption: “Stairs providing a required means of egress from an area of not more than 40 m² shall have a minimum clear width of 760 mm and the angle of inclination above the horizontal shall not exceed 50 degrees.”⁵¹ BCBC requires a maximum angle of 38 degrees inclination above the horizontal for stairs. For more on float homes and their standards, refer to the *British Columbia Float Home Standard*.⁵²



Stairs inside the Pacifica unit at Caravan – The Tiny House Hotel, Portland, Oregon. Image credit: Jeffrey Freeman

More on Appendix Q

In the United States, Appendix Q Tiny Houses was released in August 2017 to allow for the inclusion of tiny houses in the International Residential Code (IRC). They have allowed for the following in regard to accessing a loft⁵³:

- › Stairways shall be at least 17 inches (432 mm) or more at or above the handrail;
- › The headroom shall be at least 6 feet 2 inches (1880 mm) from the ceiling to the tread or landing platform nosing;
- › Stair riser widths to be at least 7 inches (178 mm) and at most 12 inches (305 mm);
- › Stair treads are calculated:
 - › The tread depth shall be 20 inches (508 mm) minus four-thirds of the riser height;
 - › The riser height shall be 15 inches (381 mm) minus three-fourths of the tread depth;

- › A loft’s landing platform shall be 18 inches to 22 inches (457 to 559 mm) in depth and 16 to 18 inches (406 to 457 mm) in height

Appendix Q Tiny Houses within the IRC allows for ladders to access lofts with the following main requirements:

- › Rung width of at least 12 inches (305 mm) with 10 to 14 inch (254 to 356 mm) spacing between rungs
- › Capable of supporting 200 pounds (91 kg)
- › Spacing needs to be consistent
- › Installed 70 to 80 degrees from horizontal

⁵¹ Float Home Committee, Government of British Columbia. “British Columbia Float Home Standard” 2013

⁵² “British Columbia Float Home Standard”; www2.gov.bc.ca/assets/gov/farming-natural-resources-and-industry/construction-industry/building-codes-and-standards/guides/2003_float_home_standard.pdf

⁵³ International Code Council. “Appendix Q Tiny Houses” 2018 *International Residential Code*; codes.iccsafe.org/content/IRC2018/appendix-q-tiny-houses?site_type=public

ENTRANCE/EXIT EGRESS

Sleeping lofts complicate egress. As noted in the sleeping loft section above, all bedrooms must have a secondary means of egress, such as a window or skylight unless sprinklers are installed. The BCBC also requires the principal entrance (or at least one door leading to the outside) to conform to exit door code requirements (9.9.9.). The minimum entrance door width is 810 mm and height 1980 mm (BCBC 9.5.5.1 Doorway opening sizes, Table 9.5.5.1). Hallway widths by code are required to be a minimum of 860 mm but can be 710 mm if a second exit is provided in the area farthest from the living area or in each bedroom served by the hallway (BCBC 9.5.4.1). This is a challenge for tiny homes, as hallways tend to be narrower than code and additional exits for narrow hallways add additional restrictions to design.

FILTRATION AND RAINWATER HARVESTING

Regulations for water filtration and rainwater harvesting are governed by the plumbing codes of each jurisdiction. Harvesting and filtering rainwater provides sufficient water to flush a toilet, to irrigate a garden, and more. To qualify for Canadian Standard Association (CSA) designation, a Water Safety Plan under the Rainwater Harvesting Systems National Standard, CSA B805-18/ICC 805-2018 is required. This increases costs to the documentation process. Eco-Sense, a Victoria-based environmental consulting service shared the following insight. “The average single-family residence will have to expect it to cost around \$2,500 to \$3,000 of our design time for standard systems, and \$2,500 for engineer costs for reviewing and stamping. That is, on average, \$5,500 outside of the costs of the actual system itself and the cost of permits.”⁵⁴ Typically, two sets of piping are required at the extraction point so that blackwater does not mix with the greywater. See more on water conservation, rainwater harvesting and other related topics in the *Metro Vancouver Design Guide for Municipal LEED Buildings*⁵⁵ report.

COMPOST TOILETS

The BCBC requires that dwellings are connected to potable water and human waste be disposed of through a sanitary drainage system. Furthermore, BCBC 9.31.5 Sewage Disposal states dwelling units must discharge into a public sewage system or into a private sewage system (a septic tank with an absorption field) where no public sewage system is available. However, there are alternative systems that can be suggested, such as composting toilets, but would have to be signed off by a professional. *The Manual of Composting Toilet and Greywater Practice* published by the Ministry of Health (July 2016), outlines performance requirements to meet when requesting an alternative solution to the BCBC.⁵⁶



Compost toilet. Image credit: Dolly Rubiano

CHASSIS/FLAT DECK

A building that contains a chassis for transport is considered factory-built housing and will comply with portions of the CSA-Z24 MH series of standards. Where the BCBC considers mobile homes certified to the CAN/CSA-Z240⁵⁷ standard as acceptable housing and are permitted under Clause 1.1.1.1. (2).g). However this exemption does not extend to on-site preparations (foundations, mountings), connection to services and installation of appliances.

⁵⁴ Eco-Sense, CSA B805-18

⁵⁵ “Metro Vancouver Design Guide for Municipal LEED Buildings”; toolkit.bc.ca/sites/default/files/Municipal_LEED_Buildings_08_Update_0.pdf

⁵⁶ “Manual of Composting Toilet and Greywater Practice.” BC Ministry of Health, Health Protection Branch; www2.gov.bc.ca/assets/gov/environment/waste-management/sewage/provincial-composting-toilet-manual.pdf

⁵⁷ CAN/CSA-Z240; techstreet.com/standards/csa-z240-mh-series-16?product_id=1913525

Foundation walls for wood-frame buildings can be made from concrete or unit masonry. Footings are required to be made of concrete. However, wood footings are permitted when wood foundation walls are permitted. BCBC provides regulations on the type of floor-on-grade (floor-on-ground is described as non-structural flooring supported on ground or on granular fill); it can be wood or concrete slab⁵⁸.

OTHER

All electrical installations temporary or permanent are required to have a permit as administered through the [BC Safety Authority](#).⁵⁹ If the building is on wheels and has temporary plumbing, electrical and gas connections, then the BC Building Code does not apply. Therefore, it must comply with the CAN/CSA Z240 RV performance standards and is regulated for gas and electrical by [Technical Safety BC](#). Equally, Transport Canada has regulations for road travel.

The installation of appliances such as gas, propane and electric cooktops require clearances (see image below) which can limit the amount of cabinetry directly above and beside the appliance.

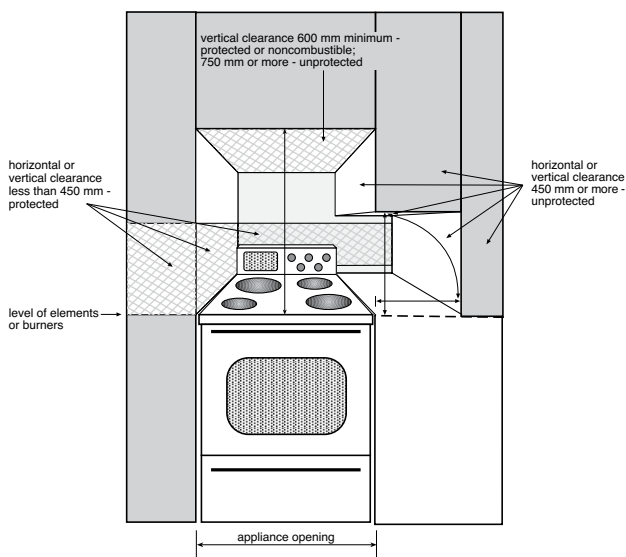

Image credit: BC Building Code Revision Package 2015

Closing the gap

Some components and design features within tiny homes do not comply with all municipal, provincial and federal codes or industry standards. To shift the conversation, we must first look to the National Building Code (NBC). The NBC forms the foundation for developing the provincial codes. The BCBC has adopted the NBC and includes requirements that are specific to the conditions of the province. Tiny homes, like other housing forms, can be designed to accommodate the different physical characteristics of each province, such as precipitation levels or climate. That said, making tiny homes an allowable dwelling unit first needs to be done at a national level before being adopted into the BCBC or other provincial building codes.

Updates to the NBC are made when there is a requirement of national importance. Affordable housing certainly falls in this category.⁵⁹ In March 2017, members from the modular construction council of the Canadian Home Builders' Association (CHBA) drafted and submitted fourteen code change requests (CCRs) to the National Building Code. Three of the code change requests spoke to provisions in Division A — two definitions and an update to the appendix note on the provision that states that the code applies to both site-built and factory-constructed buildings. These will be addressed by the executive committee of the Canadian Commission on Building and Fire Codes (CCBFC) which acts as the standing committee for Division A. The other eleven code change requests pertained to requirements in Division B Part 9 and are to be addressed by the standing committee on housing and small buildings (SCHSB).

⁵⁸ See BCBC “9.15 Footings and Foundations,” and “9.16 Floors-on-grade”

⁵⁹ Government of Canada. “Guidelines for Requesting Changes, NRC, 22 08 2017.” *National Research Council Canada*; nrc-cnrc.gc.ca/eng/solutions/advisory/codes_centre/codes_developed.html

Below is a summary of the code change requests (CCRs) made by CHBA. See Appendix B for full documentation on these code change requests.

DIVISION A: COMPLIANCE, OBJECTIVES AND FUNCTIONAL STATEMENTS

1. Clarify how (1) buildings that are built off-site but not in a factory, and (2) buildings that are built on a chassis for installation on a foundation later apply to code. Currently the code applies to site-built and factory-constructed buildings but does not mention the alternative construction methodologies that are typical of tiny houses. (CCR_Div.A, 1.1.1.1.(2))
2. Update definition of “factory-constructed” buildings to not be limited to those constructed in facilities typically understood to be factories, and include those constructed on a chassis. (CCR_Div.A, 1.4.1.2)
3. Clarify use of the word “mezzanine” and if it applies to sleeping lofts that are common design elements in tiny houses. (CCR_Div.A, 1.4.1.2)

DIVISION B—PART 9: HOUSING AND SMALL BUILDINGS

1. Clarify the definition of a “combination room” and amend the minimum opening between the two functional spaces. Currently, the requirement is a 3 m² opening, however, in some tiny homes this is not feasible due to size restrictions. (CCR_9.5.1.2.(1))
2. Revise minimum ceiling height of 2.1 m as sleeping areas are not usually allowed enough space to meet code in tiny homes. (CCR_9.5.3.1.(1),(2))
3. Allow for smaller door size in secondary suites, and Part 9 buildings; to allow more flexibility in tiny homes. (CCR_9.5.5.1.(1))
4. Clarify the requirement for minimum widths for doorways in tiny houses as it applies to rooms with a bathtub, shower or water closet. Current specifications are contingent on the width of the hallway serving that room. However, in a tiny home it is not always clear how to interpret this requirement when hallways are not always used in smaller space design. (CCR_9.5.5.3.(1))

5. Clarify that stairs are not required to be built and that when a stair is not built, handrails guard requirements for stairs do not apply. (CCR_9.8.1.1)
6. Limit the requirement of guard rails for sleeping lofts to only be required for levels with walking spaces and not on sleeping lofts with reduced ceiling heights. (CCR_9.8.8.1)
7. Exclude sleeping lofts from having an egress window in the case of a fire. (CCR_9.9.10.1)
8. Amend code so that only one smoke alarm is required in a one-storey dwelling unit where the sleeping and living space are part of a combination room. (CCR_9.10.19.3)
9. Clarify how wind loads apply to buildings on a chassis. (CCR_9.23.13.2.(2))
10. Amend code to only require one sink whereas current code requires a lavatory and kitchen sink, which is not always feasible in tiny houses. (CCR_9.31.13.2.(2))

Both committees reviewed the code change requests in May 2017 and planned to ask for an approval to work on the task. Based on the CHBA’s records, the SCHSB has not yet requested approval to work on this task, and unfortunately, the code change requests for Division A were misinterpreted as an expansion of the scope of the code rather than a simple clarification. CHBA has been working to rectify this misunderstanding. The code change request process is an arduous one and can take several years before a decision is made.

That said, reviewing the proposed code changes to the NBC is the first step of many. Inspiration can be pulled from the International Residential Code’s Appendix Q Tiny Houses procedures, findings and adoption. Once a decision is made, and amendments have been implemented into the NBC, incorporating changes into the BCBC is the next course of action—making it easier for municipalities to permit tiny houses as part of their housing stocks.

Creating a future for tiny homes

In order to introduce tiny homes as a viable and affordable housing option in B.C., we must look at our codes and standards. Currently, it is possible to build a tiny house on a permanent foundation and meet the BCBC and/or CSA A277 requirements. However, its restrictive design and smaller footprint requirements are challenged by various conditions that can ultimately lead to increased square footage. Amending the National Building Code is the preferred option to address this issue.

As for moveable tiny homes, there are no existing guidelines in place to regulate their design and construction for permanent living. To address this, the construction industry can adopt a new standard specific to tiny houses on wheels via an

industry-standard certifying body such as the CSA. This standard would differentiate the unit from recreational vehicles and park models, and ensure the structure is designated as a permitted dwelling unit for full-time living. This would allow municipalities to open their doors to tiny houses without authorizing other seasonal and motorized models.

The American Tiny House Association, along with tiny house builders and industry experts, is taking steps to do just that through the American National Standards Institute (ANSI). Such action in Canada would not only help regulate the tiny house market but also ensure that homes are built safely, and therefore, are suitable for placement in communities across B.C.



Constructing a tiny house at Go, Go TINY. Image credit: BC Tiny House Collective



Constructing the Northern Nomad. Image credit: Brigitte Martins

7 | Insurance, financing and warranty



Image credit: Cytonn Photography

Tiny houses are still a niche market in the eyes of financiers and insurers. Not all lenders and insurance providers offer services for them. This lack of consistency means prospective tiny home buyers need to look for alternative options. Furthermore, the typology tends to fall into a grey area and is sometimes not even considered a home by insurance providers⁶⁰.

This is highlighted in the research conducted by Brown titled “Overcoming the Barriers to Micro-Housing: Tiny Houses, Big Potential.” She conducted interviews and in-person site visits with tiny house residents, city staff, micro-village advocates, architects, contractors, U.S. Department of Housing and Urban Development (HUD) representatives and tiny house academics. While the biggest barrier to tiny houses and micro-villages is “often a lack of political and social support (land use ordinances and codes can be flexible but people’s stigma about tiny houses is often the most significant barriers),”

several respondents listed “accessing insurance” and financing construction” as key barriers. In fact, many noted that few banks would finance the purchase or construction of a tiny house, leading some to take out personal loans—which come with higher interest rates and without the same tax benefits associated with the purchase of a traditional home. The user satisfaction survey conducted as part of this report showed that most respondents directly financed their own tiny home (see Appendix A of this report for more on the survey, participants and findings).

⁶⁰ Brown, Emily. “Overcoming the Barriers to Micro-Housing: Tiny Houses, Big Potential”. *University of Oregon Department of Planning, Public Policy and Management*. 2016; scholarsbank.uoregon.edu/xmlui/bitstream/handle/1794/19948/Brown_final_project_2016.pdf?sequence=4&isAllowed=y



Example of an RV

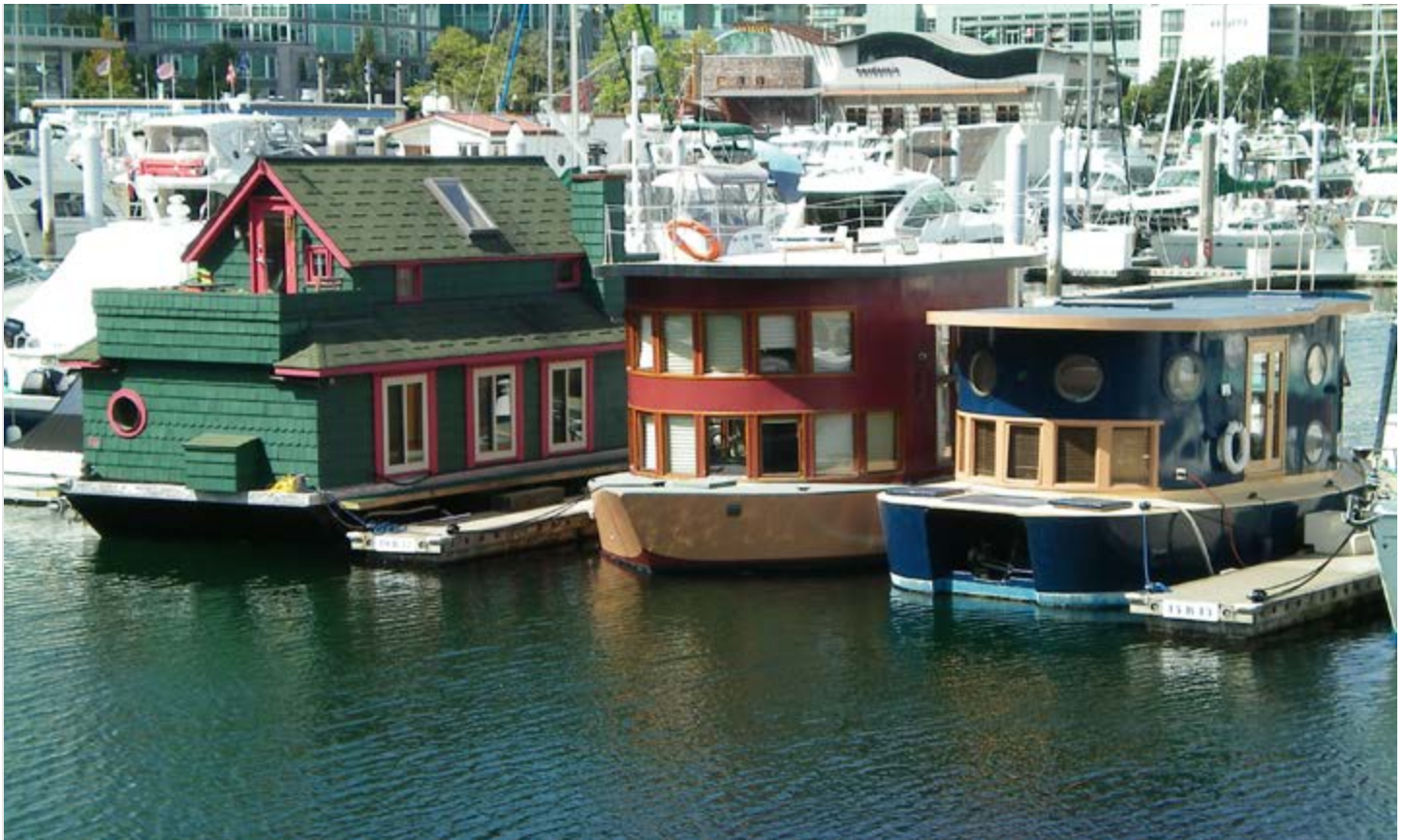

Example of houseboats

To examine this further, this section explores how other built forms—such as houseboats and recreational vehicles (RVs)—have tackled insurance, financing and warranty. They may hold the key to unlocking the future tiny house market.

Insurance

Home insurance primarily protects one's personal property and covers it against fire, theft, loss of use, personal liability, and medical payments to others. Tiny homeowners have difficulty securing adequate home insurance for their units. Some common challenges with insuring a tiny home include:

- › Tiny houses often cannot be insured as personal property, although this is the most common type of insurance applicable to tiny homes
- › Tiny homes usually cannot be covered by auto insurance because they are not self-propelled; they can only be insured through RV insurance if they are [Recreation Vehicle Industry Association](#)⁶¹ (or RVIA)-certified, which comes with its own restrictions
- › Even when tiny home residents do find a suitable insurance policy, they are often forced to find a new solution when and if their living situation changes. For example, if the owner decides to live in the unit or rents it out, they are required to find a different policy, as the latter option is considered a business⁶²

There can be unintended consequences when tiny homeowners are unable to find adequate insurance options. For instance, maintaining the unit over time may require hiring skilled labour and those workers with specific training may be unwilling to conduct repairs to a unit that is not insured. This may leave the homeowner in a precarious situation where repairs are then unofficial or off-the-record, which may not be in the tiny homeowner's best interests.

Guardian Risk Managers in British Columbia and Alberta are one of the few insurers who offer all-risk coverage for tiny houses, both permanently placed and moveable units. Their product highlights include: replacement cost settlement, competitive rates, \$2,000,000 limited liability, and enhanced coverage on personal property, power generation and solar energy equipment, towing and storage, fire department charges, sewer backup and watercraft.⁶³

Meanwhile in Portland, Oregon, Darrell Grenz Insurance (via Lloyds of London) is offering the first-of-its-kind tiny home policies for dwellings built on trailers. As of August 2019, this coverage is available in the states of Oregon, Washington, California, Utah, Arizona, Idaho, Montana, Colorado and Nevada. They hope to go national and launch other plans to cover tiny home parks, communities and construction policies in the future. Their existing coverage includes: 1) the main tiny home dwelling; 2) separate structures (if not used for commercial purposes); and 3) personal property (theft), loss of use, personal liability, and medical payments to others. (Note: Auto insurance is additional for towing/moving tiny homes.⁶⁴)

Other types of alternative living accommodations include houseboats and RVs. Each has insurance options for those who choose to live in them. Although these options are not standardized or well understood, they may set a precedence for tiny house insurance options.

⁶¹ Recreation Vehicle Industry Association; crva.ca/

⁶² Brown, Emily. "Overcoming the Barriers to Micro-Housing: Tiny Houses, Big Potential". *University of Oregon Department of Planning, Public Policy and Management*. 2016; scholarsbank.uoregon.edu/xmlui/bitstream/handle/1794/19948/Brown_final_project_2016.pdf?sequence=4&isAllowed=y

⁶³ "Tiny Home Insurance". *Guardian Risk Managers*; guardianrisk.com/products-coverage/tiny-home-insurance/

⁶⁴ Sullivan, Deirdre. "How to Get Real Insurance for Your Tiny House on Wheels". *The Spruce*; thespruce.com/get-real-insurance-for-your-tiny-house-on-wheels-3883963

HOUSEBOAT INSURANCE

There are a number of considerations when choosing to live on a boat. Similar to a mobile home, there is no land ownership but owners need to ensure coverage for contents, the structure and liability. Here are some insurance company considerations and thoughts around insuring houseboats (based on communications with various Vancouver based insurance companies):

- › How many living quarters are within the houseboat?
- › Are you living in the vessel year-round or is it moored empty part of the year?
- › Are you traveling in the vessel; and if so, how far and how often?
- › What is the cost of the vessel and are you an experienced boater?
- › How old is the vessel? If more than 15 years-old, an inspection (or survey) of the interior, exterior and engine of the boat, must be carried out by a qualified marine surveyor.

One company was happy to provide coverage assuming the survey met their requirements and the vessel was no older than 10 years. “So long as it’s safe and seaworthy, there shouldn’t be any issue.”

From an insurance perspective, there is a distinction between living on a houseboat and someone living on a boat. The main difference is that a houseboat’s primary use is to serve as a home. In the case of a sailboat, it is considered a pleasure craft and can be insured with *liveaboard* insurance. Houseboats can apply for a pleasure craft policy, but it depends on the insurer; some insurers do not offer policies at all. Houseboats may also be further classified as a “houseboat” (which moves) and a “float house” (which does not move).

RV INSURANCE

Insurance coverage for RVs is widely available in Canada. Go RVing Canada advises to consider the following when looking for RV insurance⁶⁵:

- › Coverage depends on if you are driving a motorhome, towing it or live in it year-round.
- › Liability considerations include personal injury for guests, for example, if someone trips and breaks his/ her leg while visiting your RV.
- › You may need to pay an extra premium to cover personal belongings inside the RV (some standard policies may cover contents inside and out).
- › Specializations may include total loss replacement, replacement cost of personal belongings, full-timer liability (if the RV is parked and used as a residence), campside liability (short-term vacationers), emergency expenses (including repairs), medium duty tow trucks and suspend collision coverage when in storage (allowing you to suspend portions of a policy when your RV is in storage).

Despite its wide availability, there are some myths around RV insurance as identified by Outdoorsy Canada (2017). First, there is no guarantee of receiving the insurance coverage you want. Liability coverage through a home insurance policy is “generally a no-go.” However, if renting an RV, you may not be protected under the owner’s policy. While towable RVs are not motor vehicles (and do not need their own auto insurance), Class A, B and C motorhomes do. Further, if towing a trailer, you may be covered under a vehicle’s liability insurance; but when it is parked, it is not covered by most policies. Home insurance also requires a permanent address and vehicle insurance does not cover the contents of the building. Lastly, compensation for claims vary between different insurance companies. It may be that you are only compensated for what the company deems the value of your rig while other companies will buy you a new RV.⁶⁶

⁶⁵ “What to Look for With RV Insurance”. *Go RVing Canada*; gorving.ca/buy-an-rv/rv-insurance/

⁶⁶ “The 4 Biggest Myths About Canadian RV Insurance”. *Outdoorsy Canada*; ca.outdoorsy.com/neveridle/4-biggest-myths-canadian-rv-insurance

TINY HOUSES IN QATHET

The qathet Regional District (qRD, formerly the Powell River Regional District) views tiny homes on wheels as a manufactured home and a form of affordable housing that can work well in rural areas. (qRD bylaws define manufactured homes broadly enough to capture tiny homes on wheels.) Currently, qathet has no policy or regulation that discourages tiny homes, providing they are located in areas where a manufactured home or single-family dwelling is an allowable use. A key requirement, as with all other forms of housing, is that owner-builders contact Vancouver Coastal Health to ensure that on-site water and sewer servicing comply with provincial legislation and regulation. The qathet Regional District has not adopted a building bylaw or building permit program. All owner-builders in the region are advised of provincial requirements to build to the BC Building Code and to apply for an authorization with BC Housing's Licensing & Consumer Services branch. They do, however, run the risk that their units may not be insurable. Note: Not all regional districts operate as the qathet does. For more information on regional districts in British Columbia, visit: [Regional Districts in B.C.](#)

Financing

There are many barriers when considering financing options for tiny houses. If a tiny house is not built on a foundation, mortgage financing does not apply as it is considered a chattel. If built to the Canadian CSA Z240 standard, the Chattel Loan Insurance Program (CLIP) from the Canada Mortgage and Housing Corporation (CMHC) does provide access to home mortgages for homes on chassis. Finally, perceptions about tiny houses affect financing options. Moveable tiny homes are not seen as having good resale value and because of this, cannot be used as collateral to secure a loan.⁶⁷

As outlined in this report, most participants of the tiny house user satisfaction survey financed their tiny houses through a combination of their own savings, family members and friends. Financing a tiny house is difficult and is not accessible to the majority of those that choose to live in one. Transitioning into a tiny house has significant upfront costs, and without greater industry acceptance and offerings, is out of reach for those who need affordable accommodations the most.



There are financial barriers to consider when purchasing a tiny house. Image credit: Steve Buissinne, Pixabay

⁶⁷ G. Adaire Chown, et al., "Tiny Houses in Canada's Regulatory Context: Issues and Recommendations Discussion Paper". Provincial-Territorial-Municipal Working Group on Tiny Homes, October 2, 2016; mhaprairies.ca/pdf/municipalities/Tiny%20Homes_Discussion%20Paper_2016-04-04.pdf

Home Warranty Insurance and Manufacturers Warranties

HOME WARRANTY INSURANCE

Home warranty insurance protects new homes in British Columbia against construction defects. It is one of Canada's strongest construction defect insurance coverages. B.C.'s [Homeowner Protection Act](#)⁶⁸ and its Regulations (the Act) require that all new homes constructed in B.C. must be built by a licensed residential builder. They must also be covered by home warranty insurance unless they are specifically excluded by the Act or its regulations.

Home warranty insurance protects homeowners from a range of construction defects for designated periods of time: two years on labour and materials (some limits apply), five years on the building envelope, including water penetration, and ten years on the structure. If a new home is re-sold within ten years, any remaining home warranty insurance coverage is automatically passed on to subsequent purchasers.

EXEMPTIONS FROM HOME WARRANTY INSURANCE

The most common exemption from the licensing and home warranty insurance requirements is a new home built under an Owner Builder Authorization issued by BC Housing. Under the Act, individuals wanting to build a new home for their own use are required to obtain an Owner Builder Authorization prior to commencing construction of that new home. This requirement is in effect for all areas of B.C., regardless of whether building permits are required. Owner builders must pass a basic homebuilding knowledge test, build or directly manage the construction of the new home themselves and are personally liable for any construction defects in the new home for ten years.

Homes built on First Nations land are not required to be built by a licensed residential builder and do not require 2-5-10 year home warranty insurance coverage.

MANUFACTURED HOME WARRANTIES

Under the Homeowner Protection Act, mobile or manufactured homes constructed and certified by the Canadian Standards Association (specifically CAN/CSA-A277 for factory-built homes and CSA-Z240 for mobile homes) are not required to have home warranty insurance and be built by a licensed residential builder. Since tiny homes are not generally CSA certified they will not qualify for this exemption.

While these types of homes may include warranties provided from the manufacturer, these manufacturer supplied warranties are not regulated, and vary in coverage and protection for the homeowner.⁶⁹

⁶⁸ Homeowner Protection Act and Regulations; bclaws.ca/civix/document/id/complete/statreg/98031_01

⁶⁹ "Home Warranty Insurance on New Homes." *BC Housing*; bchousing.org/licensing-consumer-services/new-homes/home-warranty-insurance-new-homes

TINY HOUSE BUILDER'S SURVEY FINDINGS

As part of this research, a survey was drafted and distributed to tiny house builders across British Columbia. The questionnaire explored form, end users (buyers), building practices, certification, financing, and warranty provisions. Responses were received from urban and rural centres, including: Halfmoon Bay, Argenta, Langley, Prince George and Burnaby.

While the survey received limited responses, it highlights diverse work practices within the industry and a need for greater standardization as it relates to warranty and construction more generally. For more information on this survey, please see Appendix C.

“They are built like any other home, with smoke detectors, wood stove, setbacks and chimneys, proper venting and so on.”

—Respondent, tiny house builder survey, 2018

Recommendations by tiny house builders on what needs changing at local, provincial and federal code levels for moveable and other forms of tiny houses:

- › Remove homeowner warranty from small houses
- › Simplify the insurance inspection process for small builders
- › A specific category or building code for sub trades to be able to pull a permit appropriately for the safety authority; at this time, it doesn't exist
- › Treat moveable tiny homes like a regular home, with the same codes

Recommendations by tiny house builders on how to regulate the construction of tiny homes:

- › Create an affordable solution for inspection
- › Have a proper building standard for tiny houses and inspections
- › Replicate similar home inspection processes, at each stage for each trade



Constructing a tiny house for go, go TINY. Image credit: BC Tiny House Collective

Moving forward

In a report by Krista Evans, she comments that current banking practices and home assessment methods sometimes misunderstand the value of tiny houses. There is a common belief that large single-family dwellings in single-use residential neighbourhoods always offer the best investment opportunities. Evans attributes this to a common industry-held, and individual belief, that mixed-use neighbourhoods decrease property values and investment opportunities. Perceptions are changing. When a New York City neighbourhood was rezoned to mixed-use, property values increased. Similar findings are coming out of Boston, Chicago and Portland. Integrating tiny houses into mixed-use neighbourhoods may result in highly sought-after communities.⁷⁰

Evans adds that the use of non-mandatory guidelines for tiny houses on wheels (THOWs) may help with insurance and financing. Guidelines can provide a “starting point for THOW dwellers to establish THOW living as a safe and viable housing option.” Tiny House Community, an online network, has developed a non-mandatory standard called “Guidelines for Tiny Houses on Wheels.” The intent is to require THOWs to be built “safely, wisely and soundly.” Adopting these guidelines does not necessarily guarantee better insurance and financing opportunities. However, they may be helpful in unifying the industry and be a step towards legitimizing and legalizing tiny house design and construction processes. The results may help alter the perceptions of financiers and insurers in a positive way.

For example, take the well-known, voluntary green building rating system LEED⁷¹. Heavy adoption of this system has resulted in international brand name recognition, and higher property values and leasing rates for LEED-certified buildings. Some municipalities even require LEED for new construction

such as the City of Vancouver’s rezoning of commercial buildings⁶³. LEED, as a guideline, has pushed the construction industry forward with requirements that exceed mandatory code and standards. These guidelines have been adopted into code, thereby influencing new standard building practices. From a financing and insurer point of view, supporting the development of LEED-certified buildings aligns with internal targets and goals, such as Responsible Property Investment, green real estate funds and Green Coverage Endorsements⁷². This “triple bottom line” approach to business (equal consideration to economic, social and environmental benefits of an action), is an increasing trend.

For THOWs, best practices are still in early stages comparatively. Establishing non-mandatory guidelines in the interim may accelerate best practices in the future, assist with construction standardization, and may help lead the direction on codes. Evans notes that when guidelines become standard, increased construction costs tend to follow. They may present an additional barrier for tiny home builders.

While there are systemic challenges to moveable tiny houses and how they are financed and insured, much can change if an industry-wide standard is created ; one that specifically addresses tiny homes on wheels. If the structures are seen as viable options, and distinct from motor homes or recreational vehicles, it might encourage traditional forms of insurance and financing to become more widely available.

⁷⁰ Evans, Krista, “Review: Integrating Tiny and Small Homes into the Urban Landscape: History, Land Use Barriers and Potential Solutions”. *Journal of Geography and Regional Planning*, Vol 11(3). March 2018. pp. 34-45, DOI: 10.5897/JGRP2017.0679

⁷¹ “Green Buildings Policy for Rezoning”. *City of Vancouver*; guidelines.vancouver.ca/G015.pdf

⁷² “Green Buildings and the Finance Sector: An Overview of Financial Institution Involvement in Green Buildings in North”. *United Nations Environment Programme*. Washington, DC: UNEP, 2010

8 | Case studies – Lessons learned

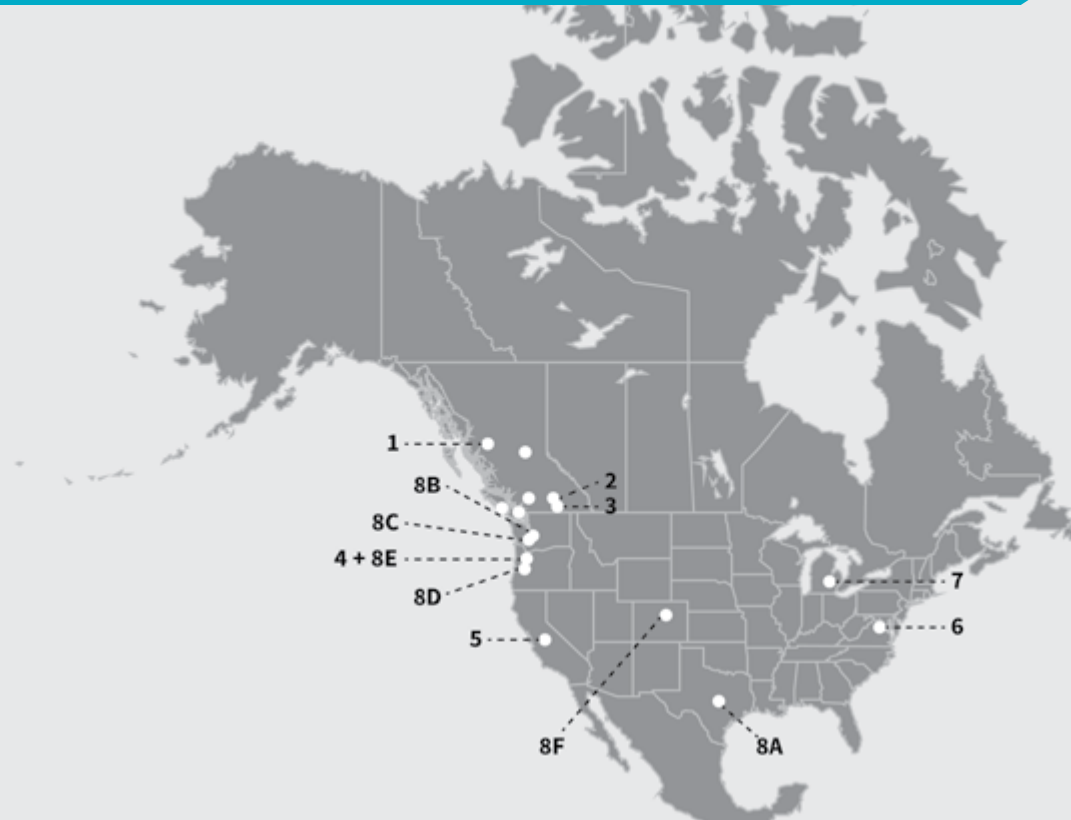

Every day new tiny house ordinances, policies, and communities are emerging in North America. The focus is not to capture everything that is happening, but rather to highlight case studies to illustrate the wide range of options and uses of this form of housing.

This section features eight case studies in 13 communities across British Columbia and the United States.

Case study no. 8 on tiny house communities includes six individual projects.

Each project is unique in terms of its city context, tiny house use and users, or partnership and funding models. These examples provide a snapshot of tiny houses in various phases—from newly approved and permanent communities, to arrangements that address temporary homeless encampments. The case studies also highlight the pros and cons, lessons learned, best practices and frameworks that other municipalities, regional districts, Indigenous

communities, faith groups, land trusts, builders, developers and community partners can replicate in future iterations.

Case study contributors verified their content in August 2019. Please contact the organization directly for the most current information.



A tiny house in the micro village. Image credit: Bluegrass Meadows Micro Village

Case study no. 1:

Bluegrass Meadows Micro Village | Regional District of Kitimat-Stikine, BC

Bluegrass Meadows Micro Village is Canada's first "legal" tiny house village. Situated within the Regional District of Kitimat-Stikine (15 kilometres outside the City of Terrace), the community was privately financed and developed by the owner of a tiny house build and design company: Hummingbird Micro Homes. The property consists of site-owned dwellings (cabins and tiny homes) available for long-term rental. Homeowners can also bring their own tiny homes on wheels to the site, but they must be CSA-certified.

bluegrassmeadows.com | hummingbirdmicrohomes.com/villages

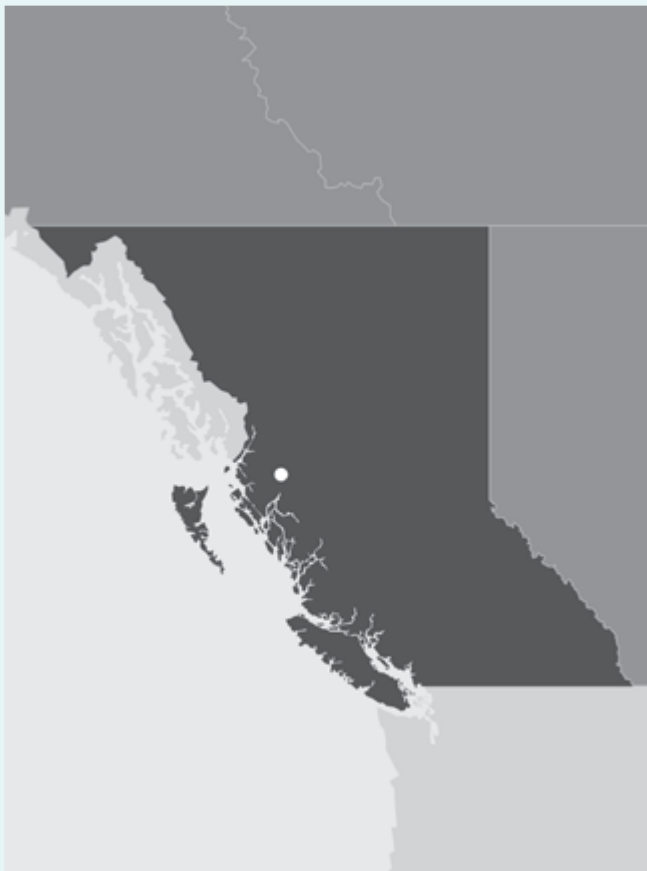

CONTEXT

Region: Regional District of Kitimat-Stikine (northern BC)

Municipality: Near the City of Terrace (15km)

Population: 37,367 (regional district; 2016 census⁷³)

Vacancy rate (rental): 4.5% in Terrace proper (2018, CMHC)

Average cost to buy a single-family home (3 bedrooms): \$300,000+ (June 2018)⁷³

The District of Kitimat-Stikine is one of 29 regional districts in B.C. Regional districts were created by the province in 1965 as a response to demands for services by residents living in areas outside existing municipal boundaries. As per the *Regional District Tool Kit* (2005), "a regional district may undertake the following types of initiatives and actions, including: prepare, adopt and administer official community plans [and zoning bylaws] for electoral areas or parts of electoral areas."⁷⁴

⁷³ 2016 census; www12.statcan.gc.ca/census-recensement/2016/dp-pd/prof/details/page.cfm?Lang=E&Geo1=CD&Code1=5949&Geo2=POPC&Code2=0420&Data=Count&SearchText=Kitimat&SearchType=Begins&SearchPR=01&B1=All&TABID=1

⁷⁴ "Regional District Tool Kit". 2005. Union of British Columbia Municipalities, Government of British Columbia; ubcm.ca/assets/library/Publications/Regional-District-Tool-Kit/Regional%20District%20Tool%20Kit-complete.pdf



Entrance of a tiny house in the community. Image credit: Bluegrass Micro Village



Interior view of the kitchen of a tiny house in the community. Image credit: Bluegrass Micro Village

Well and septic systems, in-depth

A 12,000 gallon holding tank was installed that fills throughout the night and at less busy times during the day. Five septic systems were installed with five tanks and septic fields. The tanks are pumped out every two to three years.

Tiny but not...

The village does not allow vacation rentals and RVs. It's believed they would change the look and feel of the community which is more rustic and cabin-like.

GENERAL

Location: Rural setting, on the Kalum River

Site ownership: Private

Lot size: 31 acres (mix of forest and meadow)

Number of units: 14 with one fully serviced pad; expanded to 38 cabins with 13 fully serviced pads in spring of 2020

Amenities on site: Common areas, free laundry and wifi, outdoor space, parking pads (next to units) with additional parking for guests, community garden; also pet-friendly

CONSTRUCTION

Time to construct/complete: Two years

Launch date: September 01, 2015

Site management: By owner

SERVICING

On-site services: Compost/waste/recycling collection, electrical, garbage pickup, internet, phone (tower), road access, septic tank (sewage), snow removal, and water

Permitted energy sources: Electric, propane

Metering: One for the entire site, with costs divided among residents (included in the rental fee); each unit is hooked up to water, sewage and electricity

Other sustainable services/options: Greywater filtration and management systems, rainwater collection, wind energy and solar panels

Units on site: 100 to 500 square feet, and include bathroom/kitchen facilities; each tiny house land parcel is 2,500 to 4,000 square feet

- › Cabins on permanent foundation (concrete piers, site-owned)
- › Modular tiny homes on permanent foundation (concrete piers, site-owned)
- › Modular tiny homes on temporary foundation (on high-gravel pads/piers)
- › Moveable tiny homes on permeable pads (anchored and skirted)

TENANCY, RENT AND OTHER

Requirements: Tenants must sign a BC Residential Tenancy Agreement (use online form) and provide a damage deposit (50% of the monthly rent)

Lease options: Six or 12 months with a two-month minimum and one-year maximum (with the option to extend)

Rent: Monthly, \$550 (if using your own moveable tiny house unit on a fully serviced pad), and \$775–\$1,200 (for site-owned tiny homes/cabins); includes utilities, internet, laundry, snow and garbage removal

Other: No warranties provided; repairs are done on site as needed

“We put an ad up on Kijiji for one cabin for rent this summer and received 55 applications over a two-month period (May to July 2019). We receive numerous applications from our website ad and phone calls every week from people desperate for housing. The very first question we get from every person interested in owning a tiny home is ‘where can I put it?’ Unfortunately, as of yet, there is still no answer, other than moving up to Terrace!”

—Shannon Loeber, Sales Manager and Consultant,
Hummingbird Micro Homes

DEMOGRAPHICS

- › Single women, ages 20+ (tenancy at the village’s launch was nearly 100% women over 50 years; but now they make up 60% of the population)
- › Single men, ages 20+
- › Couples, ages 30–50

FINANCING

Total cost to finance the micro-village: \$1,700,000 (land purchase, design fees, permits, legal fees, roads/clearing site prep \$600,000; 45,425 liter holding tank/pump-house/water filtration and distribution \$140,000; septic tanks and fields \$115,000; three power sheds/services/power poles \$110,000; internet/phone tower \$35,000; common area \$30,000; and cabin construction \$550,000)

Financed by: Private means

Lesson learned/advice to others

- › **Fill a gap.** They offered housing opportunities to the area during a substantial shortage; as such, they received no negative press or community resistance. Units were promoted on Kijiji (a buy and sell website) and other local rental sites.
- › **Connect with the right people.** They engaged with the regional district early on to secure electrical, septic and water treatment permits, which took two months.
- › **Be specific.** Get accurate estimates for installing servicing; this will be one of the most significant costs to establishing a tiny house village.
- › **Standardize.** Build to CSA standards, and allow CSA-certified tiny homes in cities. Through regulation you can ensure the houses are safe while providing housing that is affordable and accessible.
- › **Room with a view.** Give each parcel a fair amount of space to counter the small size of the unit; and create a common area as the homes can’t accommodate visiting friends and family.
- › **Be pet-friendly.** This will ensure the community is inclusive and reduces access barriers to affordable housing.



City of Vernon. Image credit: Adam Nagy

Case study no. 2:

North Okanagan Friendship Center Society | Vernon, BC

In 2016, the North Okanagan Friendship Center Society (NOFCS), formerly Vernon's First Nations Friendship Centre, launched a sustainable tiny house design contest. The intent was to construct the winning design and raffle off the finished unit to help fund the development of an off-reserve and intentionally self-managed tiny house co-housing community, for Indigenous youth between the ages of 19 - 29 and elders. The village was intended to serve those at-risk of homelessness or facing barriers to affordable housing.

The envisioned community was to include 20 unique moveable tiny homes (designs acquired through contest submissions) and create a lease or lease-to-own model that would bring young and elderly residents together to provide wisdom, support, social interaction and connection for one another. (Note: Land was never acquired but will be a part of future phases.)

The project, while well-intended and supported by city council and the community, was not completed. However, it serves as a learning tool for others seeking to do the same.

vernonfirstnationsfriendshipcentre.com/

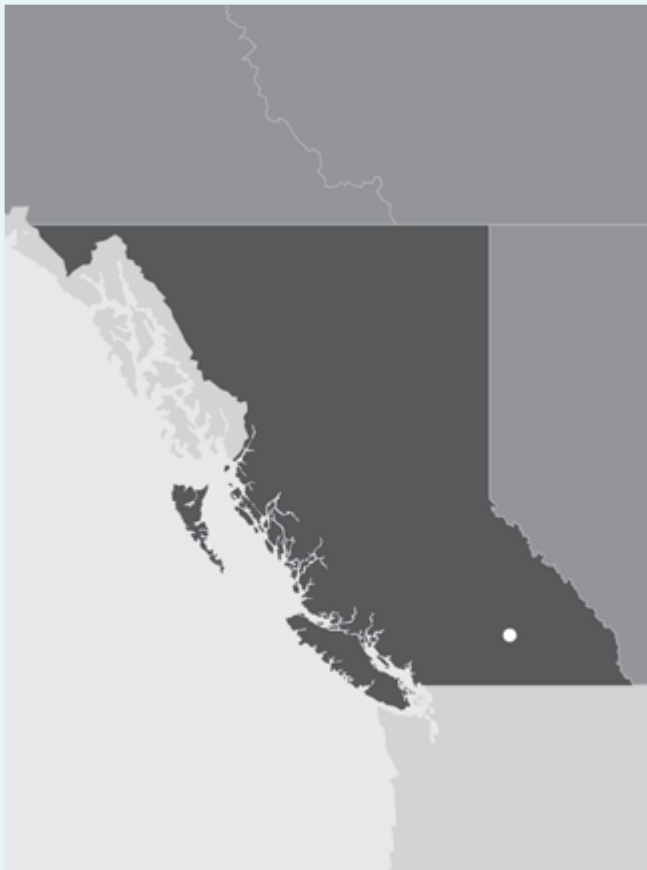

CONTEXT

Region: North Okanagan

Municipality: City of Vernon

Population: 40,116 (2016, census)

Vacancy rate (rental): 1.5% (2018, CMHC)

Average cost to buy a single-family home (3 bedrooms): \$575,000+ (August 2019, point2homes.com)

Other: NOFCS operates a 20-unit apartment complex, Kekuli Apartments, and receives on average four to five requests bi-weekly from individuals facing housing crises; most are turned away due to low/zero vacancies.

CONTEST OVERVIEW

The contest wanted to explore energy-saving building techniques and technologies through tiny house construction. The goal was to demonstrate energy efficiency as a recoverable cost; one that could be paid back over time, in order to deliver affordable housing to those in need. Three prizes were awarded: best overall design aesthetic, best use of materials and space, and best energy efficiency. In total, ten applications were received from Vernon and as far as Regina. The winning design was by architect Doug Warner.

Project timeline

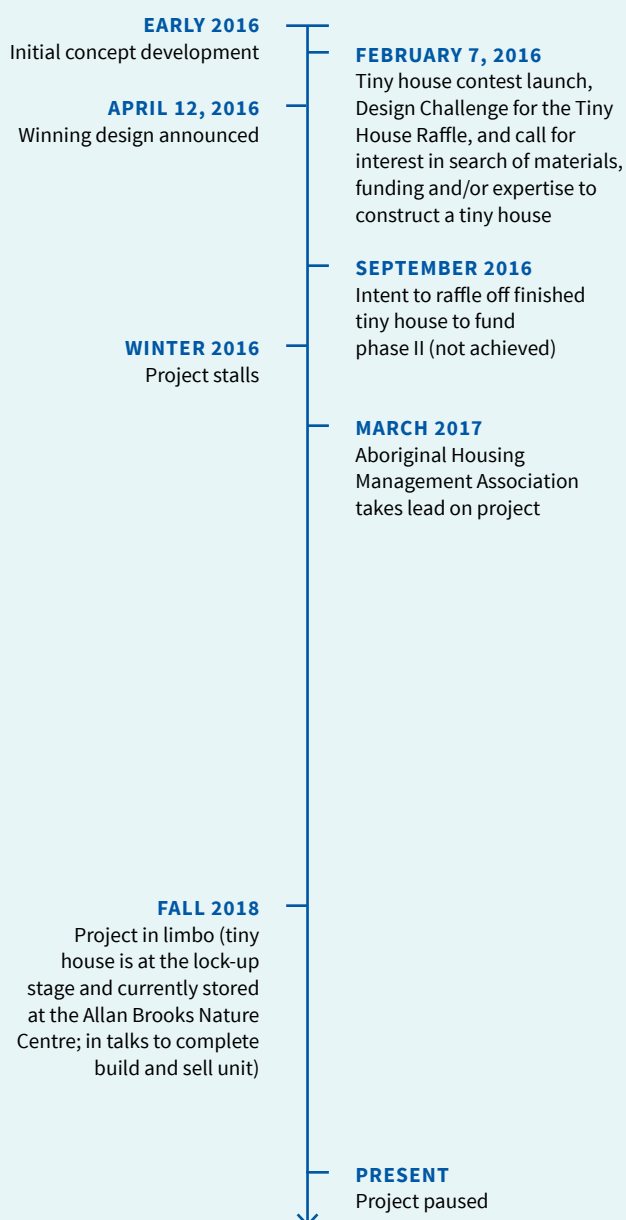

Design contest specifications

Note: The design challenge team consisted of five individuals from the construction and design industries, and the NOFCS team.

1. Size maximums: Height (13 ft/4 m), length (28 ft/ 8.5 m) and width (8.6-10 ft/2.6 m-3.04 m)
2. Must include a kitchen, bathroom, beds; designed for a family of two adults and one child maximum
3. Can include a loft area
4. Must be able to connect to city services and/or independent well and septic; can be designed 100% off-grid
5. Allows solar panels, 12-volt and 110- volt wiring/propane
6. Allows for passive heating and cooling
7. Has a designed wall system that does not include a vapour barrier
8. May show new high-tech materials and innovative storage features
9. May include unique solutions of recycling water, rain catchment or other energy saving features
10. Can either be transportable on trailer or transferred onto a flatbed truck to ship
11. Can use natural building materials but not required, for example: wood versus high-tech composites
12. Should protect from electromagnetic (waves emitted from electrical wiring)

FINANCING

- › **Total cost to finance:** \$20,000 (administration, NOFCS), funds from Aboriginal Housing Management Association (AHMA), \$50,000+ in-kind labour and materials, private donors; \$162,900 (anticipated costs to develop tiny house trades training program in partnership with Okanagan College)
- › **Expected earnings from raffle:** \$75,000

PROJECT SUCCESSES

- › **Well backed.** The project garnered committee and city council support, as well as, community financial backing through countless partnerships and in-kind donations. To date the program has not been offered again.
- › **Partnership and project legacy.** NOFCS is in discussions with Okanagan College's Sustainable Construction Management Technology Program to develop a transportable tiny house apprenticeship trades training program. The proposed 12-week classroom program would be devoted to shop instruction and include topics such as: construction safety, essential/employment skills, hand and power tools, exterior and interior construction (including roofing and window installation), HVAC, plumbing and electrical systems, sustainable and renewable design and materials, and project planning. The anticipated program plan ran from February to September 2016 as a pilot. It included training module development, strategic planning, promotions and advertising, screening applicants, preparing materials for construction, a pre-run training program, applicant review and selection, and delivery of 12-week sessions.

PROJECT CHALLENGES

- › **Budget.** Having all the supplies and materials donated or budgeted prior to construction, including a trailer, would have helped to overcome some of the project challenges for this sustainable tiny house design contest.
- › **Construction in limbo.** Building a winning design was impacted by time, issues faced bringing concept to code, and the unit was not fastened on a moveable structure (on wheels) but required a crane to move, which is costly.

Lessons learned

- › **Expertise.** Planning, coordination and experience are key elements that contribute to the success of a project when using a tiny house design contest approach.





View of Grand Forks. Image credit: City of Grand Forks



Closer aerial view of Grand Forks after flooding. Image credit: Global News

Case study no. 3:

City of Grand Forks | Grand Forks, BC

On June 13, 2016, Grand Forks City Council directed staff to undertake a review of its Official Community Plan (OCP), and requested public and stakeholder feedback on permitting innovative housing types, including small, cluster and eco-homes. In March 2018, the [OCP and zoning bylaws were amended](#)⁷⁵ to permit tiny houses on wheels (including tiny homes on foundations), and garden suites in all residential-zoned properties, and outright in all industrial zones⁷⁶.

The first tiny house [application](#) was submitted and a permit was approved in August 2018. It was located in a floodplain in the Agricultural Land Reserve (ALR) in the R4 rural residential zone⁷⁷. The applicant's home had been destroyed by flooding earlier in the year. The case demonstrates the use of tiny homes as an emergency response to housing need, serving as temporary shelter that can transition into permanent living.

(Note: The fees for this case were waived given the immediate need for alternative shelter; the tiny house is not BC Building Code-compliant.)

In July 2019, city council approved a communications strategy to let citizens know that tiny houses are allowed in the city with a Temporary Use Permit; council also waived the application fees.

CONTEXT

Region: West Kootenay

Municipality: City of Grand Forks

Population: 4,049 (2016, census)

Vacancy rate (rental): 0% (August 2019, City of Grand Forks)

Average cost to buy a single-family home (3 bedrooms):
\$429,420 (July 2019⁷⁸)

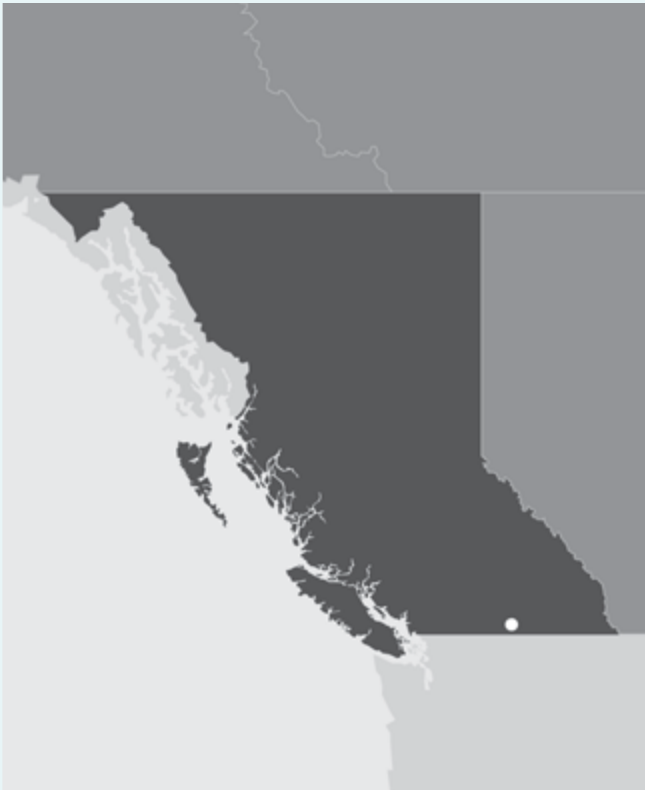

⁷⁵ "Official Community Plan and Zoning Bylaw Renewal – March 26, 2018". Development, Engineering & Planning Department. *City of Grand Forks*; grandforks.ca/development-and-engineering-notice/official-community-plan-and-zoning-bylaw-renewal-march-26-2018/

⁷⁶ The City of Grand Forks defines a *watchperson's quarter* as a "dwelling unit that may be provided for the use of one person and their immediate family, who is providing on-site security services." See grandforks.ca/wp-content/uploads/bylaws/By2039-Zoning-Bylaw.pdf, page 8

⁷⁷ "Temporary Use and Development Permit Application 6379 12th Street - Proposed Tiny House on Wheels" City of Grand Forks; pub-grand-forks.escribemeetings.com/filestream.ashx?DocumentId=6133

⁷⁸ Zolo.ca

ENGAGEMENT

The City of Grand Forks conducted extensive public outreach before adopting its tiny house ordinance. In February 2017, a review panel workshop was held to discuss affordable and sustainable housing (theme 2) as they relate to revisions of the OCP.

A survey was drafted, promoted and shared on the radio over a 10-day period in January 2018. Its intent was to capture the community's experiences in terms of housing affordability. A total of 124 surveys were completed, both online and in-person. The majority of respondents had lived in Grand Forks for more than 10 years.

Survey questions, answers and quick facts

- › **73% of respondents were homeowners**, with the remainder mostly renters
- › **72.6% currently live in single-detached homes** with the next highest percentage living in manufactured homes (9.76%); the remaining reside in townhomes, apartments/condos, secondary suites, duplexes, trailer homes, basement suites or rooms within a house
- › **56.7% said they spent 30% to 50% of their net monthly income** on housing and utilities; 17.5% pay more than 50%
- › **Over 20% planned to downsize** to a smaller or more affordable home
- › What type of housing would you prefer to live in, if available? The top three survey responses were:
 - › Single-detached home: **66.4%**
 - › Small home: **31.9%**
 - › Tiny house: **10.1%**

Why tiny in Grand Forks?

An excerpt from *A Guide to Tiny Houses in Grand Forks* (see Appendix E):

Tiny houses provide an alternative housing solution for a variety of people, including those who would like to downsize, relatives of homeowners, aging parents and renters. They can provide extra rental income to help reduce housing costs (mortgage helpers), and increases options for affordable rental housing within the city. Tiny houses use very little city infrastructure, providing a sustainable and economical way to increase and diversify housing stock in Grand Forks.



79

⁷⁹ Progress Continues on Tiny House on Wheels” My Grand Forks Now. September 2018; mygrandforksnow.com/9050/progress-continues-on-tiny-house-on-wheels

According to the City of Grand Forks, a **tiny house on wheels is: a dwelling unit⁸⁰ on wheeled chassis, greater than 12 square metres and less than 29 square metres (129 to 312 square feet), designed to be used as a full-time residence in this climate.** Tiny houses on wheels must comply with [Section 14.10 of the Official Community Plan⁸¹](#) and [Section 23 of the Zoning Bylaw⁸²](#). This includes:

- › **23.1** A tiny house on wheels must be constructed to be used as a full-time residence according to the current British Columbia Building Code or the CSA Z240 or Z240RV standard if it is pre-manufactured.
- › **23.2** For residential zones permitting a single-family dwelling with a floor area between 18 and 29 square metres or a garden suite, the tiny house on wheels must be converted to a single-family dwelling or a garden suite by placement on a full-depth perimeter or point-support foundation, subject to the conditions of a building permit from the city.
- › **23.3** A person must obtain a Temporary Use Permit to place a tiny house on wheels that is not converted to a principal dwelling or garden suite, in a zone where it is not permitted, such that: (a) bonding sufficient for removal of the tiny house on wheels is provided to the city before the time of placement; and (b) the tiny house on wheels is removed at the end of the permit period; or (c) to remain on the property the tiny house on wheels must be converted as per subsection 23.2.

OTHER TINY HOUSE REQUIREMENTS

- › The tiny house can either be a second smaller home on a lot (as a laneway), or in some cases, the only home on site.
- › As per guidelines within the OCP, the design and form of the tiny house must maintain the character of the neighbourhood and be built in a sustainable manner.
- › The tiny house unit must be serviced using temporary RV connections, unless it is functioning as a laneway house, in which case it must be connected to municipal services from the main house.
- › To place a tiny house on wheels on a lot, you must apply for a combined [Development and Temporary Use Permit⁸³](#), each site is reviewed on a case by case basis. Obtaining a permit takes roughly two months and cost's approximately \$950 (\$200 for the Development Permit and \$750 for the Temporary Use Permit); the fees are intended to cover staff resources to process the application, public notification process, land titles and any legal fees.
- › The tiny house owner is eligible for two, three-year extensions for a maximum period of six years, after which the owner needs to put the tiny house unit on a permanent foundation or reapply and pay the appropriate fees.

⁸⁰ According to the City of Grand Forks, a *dwelling unit* “means a building or a part of a building in which a person(s) live(s). This means one or more rooms are to be used as or designed as a residence, which contains sleeping, cooking and sanitary facilities and has an independent entrance, either directly from outside a building or from a common hallway inside a building.” This includes tiny houses on wheels.
See grandforks.ca/wp-content/uploads/bylaws/By2039-Zoning-Bylaw.pdf, page 4

⁸¹ “Section 14.10 of the Official Community Plan”. *City of Grand Forks*; grandforks.ca/wp-content/uploads/bylaws/By1919-A2-OCP-Amendment.pdf

⁸² “Section 23 of the Zoning Bylaw”. *City of Grand Forks*; grandforks.ca/wp-content/uploads/bylaws/By2039-Zoning-Bylaw.pdf

⁸³ “Combined Development and Temporary Use Permit” *City of Grand Forks*;
bctinyhousecollective.com/wp-content/uploads/2019/09/Grand-Forks_Tiny-House-on-Wheels-Combined-DevelopmentTUP.docx



A Grand Forks neighbourhood during the flood in 2018. Image credit: City of Grand Forks

STEPS TO GO TINY IN GRAND FORKS

1. Review the regulations and guidelines for tiny houses on wheels in the Zoning Bylaw and the Official Community Plan.
2. If you are planning to place a tiny house on a residential property, you must apply for a combined Development/Temporary Use Permit. Before you proceed, contact city staff to discuss the application requirements (250-442-8266 or info@grandforks.ca).
3. Prepare your plans and apply for a combined Development/Temporary Use Permit, which includes a questionnaire to ensure your application meets the guidelines for tiny houses in Grand Forks. When you are ready, contact city staff to book an appointment to submit your application.
4. As a first step, your application will be forwarded to city council, for authorization to proceed with public notification. This includes advertising in the local paper and notifying neighbouring property owners (within 30 metres of the applied property). All written comments will be shared with city council when it considers a permit application for final approval.
5. Your application will then proceed to council to approve (or deny) the permit. Based on public feedback or comments. The combined Development/Temporary Use Permit will be issued and valid for a period of three years. A renewal for an additional three years can be applied for prior to the expiry date of the original permit.
6. You may apply for a building permit⁸⁴; once this step is complete.
7. When all permits are in hand, you are ready to build or place the tiny house on your land.

FORESEEN CHALLENGES

- › **Many unknowns.** The City of Grand Forks may allow compost toilets in tiny homes, however, this is reviewed on a case by case basis. This may require an agreement to be drafted and signed. Staff need to develop processes as applications are submitted as there are many variations with the existing tiny home application forms. The city is receptive to permitting fully off-grid tiny houses but require a Temporary Use Permit. A security deposit may be required to cover relocation costs in the event of an emergency.
- › **Servicing.** Must meet BC Building Code requirements, which are hard to change. However the city process will evolve as more “non-exception” applications are received.

⁸⁴ “Application for Building Permit.” *City of Grand Forks*; grandforks.ca/wp-content/uploads/BuildingDocs/City-Building-Permit-Application.pdf



Caravan-The Tiny House Hotel. Image credit: Jeffrey Freeman

Case study no. 4:

Caravan – The Tiny House Hotel | Portland, OR

Caravan – The Tiny House Hotel opened its doors in July 2013 as the world’s first tiny house hotel. Located in Portland, Oregon, it is privately funded and managed. It uses the KOA⁸⁵ campground model to circumvent temporary living, zoning and building codes. Units on site are designed by local tiny house builders but do not comply with any certifiable standard. However, they do meet tourist accommodation requirements. The hotel is situated on a converted car lot and requires city bylaw variances for setup.

tinyhousehotel.com/



CONTEXT

Region: Northwest Oregon

Municipality: Portland, Oregon
(in the Alberta Arts district)

Population: 647,805 (2017, US census)

Vacancy rate (hotel, high season): 90% occupancy

Average cost to rent a hotel room in Portland per night (Airbnb included, high season): \$185 per night
(2019, Caravan)

⁸⁵ KOA campsites; koa.com



Interior of Skyline tiny house unit. Image credit: Jeffrey Freeman

Hotel facts

- › Rates are based on double occupancy (as of 2018)
- › Low season (October 1 to April 30): \$125/night
- › High season (May 1 to September 30): \$185/night
- › \$25 one-time-fee to stay in pet-friendly units
- › Cancellation requires seven days advance notice
- › Check-in 4:00 p.m. – 5:30 p.m. and check-out by 11:00 a.m.

Demographics

- › On average, guests are 40 – 50 years old, but ages range from 20 – 80 year olds
- › 50% west coast travelers from California, Washington and B.C. (mainly Vancouver), 50% are interested in living small or going tiny

GENERAL

Site ownership: Private

Lot size: 4,125 square feet

Number of units on site: Six

Amenities on site: Tied into municipal servicing (water, electrical, sewer); internet but no TV or phones

CONSTRUCTION

Time to construct/complete: Two years, August 2011 to July 2013

Launch date: July 2013

Site management: Kol Peterson (owner)

UNITS

The six units on site are mobile tiny homes designed by local builders from Olympia, WA and across Oregon. They are lifted and placed on blocks; they are not anchored or skirted, therefore their wheels are exposed. Homes are between 120 to 170 square feet, and rest on a parcel of land that is roughly 55 by 75 feet. Units are cleaned daily and roughly \$200 is spent each year on maintenance per unit.

OVERVIEW OF THE TINY HOUSE HOTEL

As stipulated by Oregon state law, the tiny house hotel is classified as a campground, and therefore, the homes can only be used on a temporary basis. Visits cannot exceed 31 days at a time. The hotel uses the KOA private campground model which allows unpermitted structures such as yurts, (but only temporarily) and RV park code standards for servicing tie-ins: of sewer, water and electricity. There is no parking lot on site, but a repossessed car lot is available for residents to use. No motorized vehicles are allowed on the property, other than units on trailers. The hotel falls under state regulation as a tourist accommodation. Therefore, it is inspected annually by the county to ensure washrooms are clean, fire detectors are functional, and fire extinguishers are present and operational.

FINANCING

Total cost to finance: \$75,000 to develop the lot, including servicing and the cost to construct the tiny houses

Financed by: Private means

Lessons learned

- › **Things are always changing.** There has been a slight dip in occupancy rates in recent years due to Airbnb, a competing tiny house hotel in Portland, and a drop in tiny house appeal (over the peak).
- › **Be bold and creative.** Create housing options that are truly affordable and consider moveable units as part of the solution.
- › **Reduce rules.** Regulations may increase costs. Consider allowing alternative foundation types and explore performance-based incentives rather than meeting set standards that may increase fixed hard costs, like pouring concrete foundations.
- › **De-regulate housing policies.** Permit moveable tiny homes as a form of de-regulated housing on a permit basis with a renewable license. This allows people to experiment and create truly affordable housing. As a result of the housing crisis in Oregon, many cities are relaxing the enforcement of unpermitted housing including vehicles, vans, RVs and tiny houses on wheels. This is an opportunity to start thinking outside the box.



Interior of Tandem tiny house unit. Image credit: Jeffrey Freeman



Interior of Kangablue tiny house unit. Image credit: Jeffrey Freeman



Pacifica tiny house unit. Image credit: Jeffrey Freeman



Fresno skyline. Image credit: Grant Porter

Case study no. 5: City of Fresno | Fresno, CA

The City of Fresno in California is believed to be one of the first municipalities in the United States to permit moveable tiny homes as accessory dwelling units (ADUs) or laneway houses. Championed by city councillor Esmeralda Soria, the new ordinances were adopted on January 3, 2016 and were enacted as part of the city's development code update. (The previous zoning ordinance was repealed and replaced by the new one).

Since its adoption, the city has not received any permit requests for moveable tiny homes (August 2019).

Note: The City of Fresno uses the term “mobile” in reference to tiny houses and its program.

fresno.gov/darm/wp-content/uploads/sites/10/2018/01/Tiny-Homes-submittal-requirements.pdf



CONTEXT

Region: Central California

Municipality: City of Fresno

Population: 527,438 (2017)

Vacancy rate (rental): 3.12% (2017, US census)

Average cost to buy a single-family home (3 bedrooms):
\$250,000 USD (April 2019, *The Business Journal*)



See videos on tiny homes in Fresno at The Fresno Bee: fresnobee.com/news/business/biz-columns-blogs/real-estate-blog/article54581715.html

According to the City of Fresno, a tiny house is a “structure intended for separate, independent living quarters for one household” that meets these six conditions⁸⁶:

- › Licensed and registered with the California Department of Motor Vehicles and meets ANSI⁸⁷ 119.2 or 119.5 requirements
- › Towable by bumper hitch, frame-towing hitch or fifth-wheel connection. Cannot (and is designed not to) move under its own power. When sited on a parcel per requirements of this code, the wheels and undercarriage shall be skirted (see Section 1 for more on anchoring, skirting and hitches)
- › No larger than allowed by California State Law for movement on public highways⁸⁸
- › At least 100 square feet of first floor interior living space
- › Detached self-contained unit which includes basic functional areas that support normal daily routines such as cooking, sleeping and toiletry
- › Designed and built to look like a conventional building structure

In the City of Fresno, a tiny house is considered an accessory dwelling unit and falls under the *backyard cottage* category. A mobile tiny house may be considered a backyard cottage if it meets these requirements:

- › Provides separate, independent living quarters for one household
- › Is attached, detached or located within the living areas of the primary dwelling unit on the lot
- › Contains kitchen facilities, including cooking appliances
- › Will be located behind the primary dwelling unit, unless attached and integral to the primary dwelling unit

Abridged tiny house guidelines as taken from the city’s program literature and municipal codes pertaining to mobile tiny homes (and backyard cottages more generally)⁸⁹ state:

- › A tiny house or backyard cottage is not allowed as a primary dwelling unit
- › Only one accessory dwelling unit is permitted per lot
- › The Director of Planning and Development must review the design of any tiny house to ensure it is compatible with the main house and neighbourhood, as a measure to maintain the character of single-family areas
- › If visible from a public street or park, the architectural design, roofing materials, exterior materials and colours, roof pitch and style, type of windows and trim will be almost the same or visually compatible with the primary dwelling
- › Minimum lot size for backyard cottage is 6,000 square feet (interior lot size) and 5,000 square feet (corner lot size)

⁸⁶ “Tiny Homes.” Development and Resource Management Department. City of Fresno; fresno.gov/darm/wp-content/uploads/sites/10/2018/01/Tiny-Homes-submittal-requirements.pdf

⁸⁷ ANSI; ansi.org

⁸⁸ In the State of California, the maximum vehicle width is eight-feet and six-inches, and height is 14-feet measured from the surface upon which the vehicle stands. Oversized vehicles require special permitting

⁸⁹ For the City of Fresno’s municipal Code of Ordinances on secondary dwelling units, backyard cottages and accessory living quarters, see Section 15-2754 at library.municode.com/ca/fresno/codes/code_of_ordinances?nodeId=MUCOFR_CH15CIDECOINRE_PTIIBAOVDI_ART9RESIMIDIRS_S15-903DEMADEST

- › Maximum floor area of habitable space for a backyard cottage is 440 square feet; maximum building height of 30 feet
- › Units shall conform to the height, setbacks, lot coverage and other zoning requirements of the district in which the site is located
- › Entrances from a backyard cottage shall not be visible from the street, unless the parcel is a corner parcel and the entrance is oriented to the opposite street of the primary residence
- › If detached, there shall be a minimum of six feet from the primary residence, or 10 feet if there is an entry from either one of the units into the space between
- › All mechanical equipment will be incorporated into the structure of the mobile tiny house and will not be located on the roof
- › Separate utility meters and/or addresses are not permitted
- › Concrete pad where the tiny house will be parked and the tiny house must be connected to municipal services: sewer and water (both reviewed by the Building Department)
- › The primary residence must be owner-occupied, allowing the secondary dwelling unit or backyard cottage to be rented. The property owner enters into a restrictive covenant with the city, which will be recorded against the property, and will prohibit the rental of both units at the same time. It will also maintain the strata title separate from the rest of the property
- › No additional parking is required for backyard cottages
- › A driveway must be provided, as per the underlying district
- › An all-weather surface path (pedestrian access) to the unit must be provided from the street frontage

PAPERWORK TO SUBMIT

- › Zoning Clearance application⁹⁰
- › Building permits for planning approval⁹¹
- › Scaled and dimensional site plan/plot plans (3)
- › Elevation drawings or pictures of proposed structure (3)
- › Operational Statement template⁹²
- › Recent title report
- › Owner authorization or owner signature on application⁹³ (indemnity agreement and a covenant verifying owner-occupancy of at least one of the two units (primary dwelling or ADU))
- › Official documentation from Pacific West Associates, National Organization of Alternative Housing or similar agency or certified entity, verifying that ANSI standards are met
- › Approved permits and paid fees

Permits

- › Grading permit regarding concrete pad
- › Utility permits for municipal service connections

Fees

Total: \$1697 + building permits

- › Zone clearance⁹⁴: \$328
- › Traffic level 2 review fee: \$275
- › Covenant fee: \$1,094
- › Building permits: Processed separately

⁹⁰ "Single Family Residential/Duplex Zone Clearance Application Form". *City of Fresno*; [fresno.gov/darm/wp-content/uploads/sites/10/2016/10/SingleFamilyDuplex-ZC-App.pdf](https://www.fresno.gov/darm/wp-content/uploads/sites/10/2016/10/SingleFamilyDuplex-ZC-App.pdf)

⁹¹ "Building and Safety". *City of Fresno*; [fresno.gov/darm/building-safety](https://www.fresno.gov/darm/building-safety)

⁹² "Operational Statement Template". *City of Fresno*; [fresno.gov/darm/wp-content/uploads/sites/10/2016/10/Op-Statement-Template-July-2017.pdf](https://www.fresno.gov/darm/wp-content/uploads/sites/10/2016/10/Op-Statement-Template-July-2017.pdf)

⁹³ "Letter of Owner Authorization". *City of Fresno*; [fresno.gov/darm/wp-content/uploads/sites/10/2016/10/Owner-Authorization.pdf](https://www.fresno.gov/darm/wp-content/uploads/sites/10/2016/10/Owner-Authorization.pdf)

⁹⁴ "Zone Clearance". *City of Fresno*; [fresno.gov/darm/wp-content/uploads/sites/10/2016/10/ZC-Handout-Final_Rev.pdf](https://www.fresno.gov/darm/wp-content/uploads/sites/10/2016/10/ZC-Handout-Final_Rev.pdf)



AMERICAN TINY HOUSE ASSOCIATION

INSIGHTS FROM DANIEL FITZPATRICK, DIRECTOR OF GOVERNMENT AFFAIRS AND ADVOCACY, STATE OF CALIFORNIA, AMERICAN TINY HOUSE ASSOCIATION (ATHA)⁹⁵

Note: The ATHA is making major inroads with the government to affect change at the local and state levels, in order to allow moveable tiny houses as ADUs. The American National Standards Institute (ANSI) is also working with the ATHA and tiny house builders to develop a tiny house specific building standard that would supersede the existing RV and park models, ANSI 119.5 and 119.2 respectively (similarly, park model and RV CSA standards).

California's coastal areas and cities, where housing and rent costs are highest, are seeing the greatest demand for tiny houses. This includes the Bay Area, Los Angeles, San Francisco, Ventura, San Luis Obispo and wine country. Additionally, tiny housing is being used in areas of California hit by wildfires in the past five years.

“Affordable housing is a major municipal concern and providing such housing requires significant public investment to subsidize costs to a level affordable for low- and moderate-income households. Moveable tiny homes, used in an accessory dwelling unit format, cost the municipality ZERO in subsidy. The property is already served with basic utilities to tie into a tiny home placed in a backyard and can be installed in several days at minimal cost. Municipalities should encourage and embrace tiny houses and moveable tiny houses as accessory dwelling units to begin addressing the pressing need for affordable housing.”

⁹⁵ American Tiny House Association (ATHA); americantinyhouseassociation.org/

Lessons learned

- › **Wheels, on or off.** If the tiny house's wheels stay on, consider using a concrete-paved or gravel pad. If the wheels are off, ensure the house foundation meets the requirements of a manufactured home standard.
- › **No imitations please.** Permitting tiny houses on wheels isn't a gateway for RVs and mobile homes. Rather, this should only be a concern if your ordinances aren't written correctly. Points to consider: specify that the house can't be motorized, require pitched roofs that exclude RVs and other similar vehicles, or use graphics that illustrate a typical moveable tiny house versus a conventional RV. The [County of Placer](#)⁹⁶ depicted this in its draft ordinance.
- › **Standards.** Require certification of units by qualified third party inspectors to ensure ANSI (or in Canada, CSA) standards are met.
- › **Next steps.** Ordinances are fairly detailed. It won't take much time to develop regulations, process applications forms—once the ordinances are drafted and approved by council. There are a number of cities and counties that have drafted tiny house ordinances that can be used to create customized municipal applications. The cities of Los Angeles and San Diego are pending on the approval of their ordinances; while Fresno and San Luis Obispo have enacted this type of law.



⁹⁶ Zoning Text Amendment – Tiny Houses (PLN18-00286)⁹⁶. *County of Placer*; placer.ca.gov/DocumentCenter/View/33073/08A-PDF



Tiny house showcase. Image credit: Boneyard Studios

Case study no. 6: Boneyard Studios | Washington, DC

Formed in 2011, Boneyard Studios was a grassroots housing initiative founded by collaborators Brian Levy, Jay Austin and Lee Pera. Together they developed a tiny house open house (and construction site) on a privately owned, under-used urban alley lot in Washington, DC. The intent was to highlight the positive attributes of smaller sustainable living spaces and promote tiny homes as an alternative affordable housing option. Public engagement took place through site tours, workshops and on location events. The collective also used this opportunity to suggest how vacant lots, throughout the city could be used creatively in support of affordable infill housing.



Brian Levy purchased the lot in March 2012. In late 2014, Boneyard Studios received a letter of complaint from the Department of Consumer and Regulatory Affairs. The property was bought by Micro Built LLC in December 2015; Boneyard Studios closed its doors the same year.

While the [project heralded nationwide media coverage⁹⁷](#) and community support, and was championed as innovative and forward-thinking, it wasn't without its challenges: regulatory infractions, and project dissolution were a few. Still, the project offers lessons that may be of value for future pilot projects.

boneyardstudios.org

⁹⁷ Media coverage; boneyardstudios.org/press/



Matchbox tiny house. Image credit: Boneyard Studios

CONTEXT

A snapshot on housing in Washington, DC

In the past, housing pressures were low. Work opportunities grew in the late 1990s, and D.C. attracted more attention. Following the mortgage crash in 2008, a new mayor was elected into office and city services improved, causing a hiring increase.

One-third of the city's housing supply is now single-family homes, two percent of the land is vacant and roughly 4,000 to 4,500 units (mostly multi-family) are being built per year. The cost of purchasing a single-family home is on the rise, with prices ranging between \$600,000 to \$700,000 for a 1,200 to 1,800 square foot dwelling unit.

The District has a lot of rowhomes with secondary suites or *English basements*. In 2016, policies related to alley dwellings were expanded to allow for ADUs on a lot. However, most alleyways are non-compliant as they don't meet emergency response access width requirements. The city needs more housing to address its population growth. Over 6,000 to 8,000 people are moving into the district each year; half are newcomers, and the other are domestic residents.

The site and showcase

The exhibit was in the residential (R-3) Brookland district, near the metro and a Catholic university, and bordered by a graveyard. This area is zoned to permit row homes on small lots. It includes areas mixed with detached and semi-detached dwellings and groups of three or more row homes. It's an irregular, triangular shaped 5,240 square foot lot. D.C. codes do not permit the construction of dwellings on a foundation, on an alley lot unless the alley width is 30 feet or greater. One of the project's goals was the amendment of D.C. alley codes to permit the development of habitable structures, and the creation of a full-time tiny house village.

Three units were displayed on site, with the intent that no one would live in the structures on a permanent basis. This included two off-grid, self-designed and 'built on-site' tiny houses on wheels (140 and 145 square feet, owned by two of the collaborators), an eight by 16-foot moveable tiny home and a shipping container. The largest tiny house on site, named Matchbox, received an American Institute of Architects (AIA) award for design.

Proposed land improvements included an 8-foot by 20-foot garage storage structure, and gravel pads for long-term parking for four to five tiny houses. Plans also included a community garden.

PROJECT TIMELINE

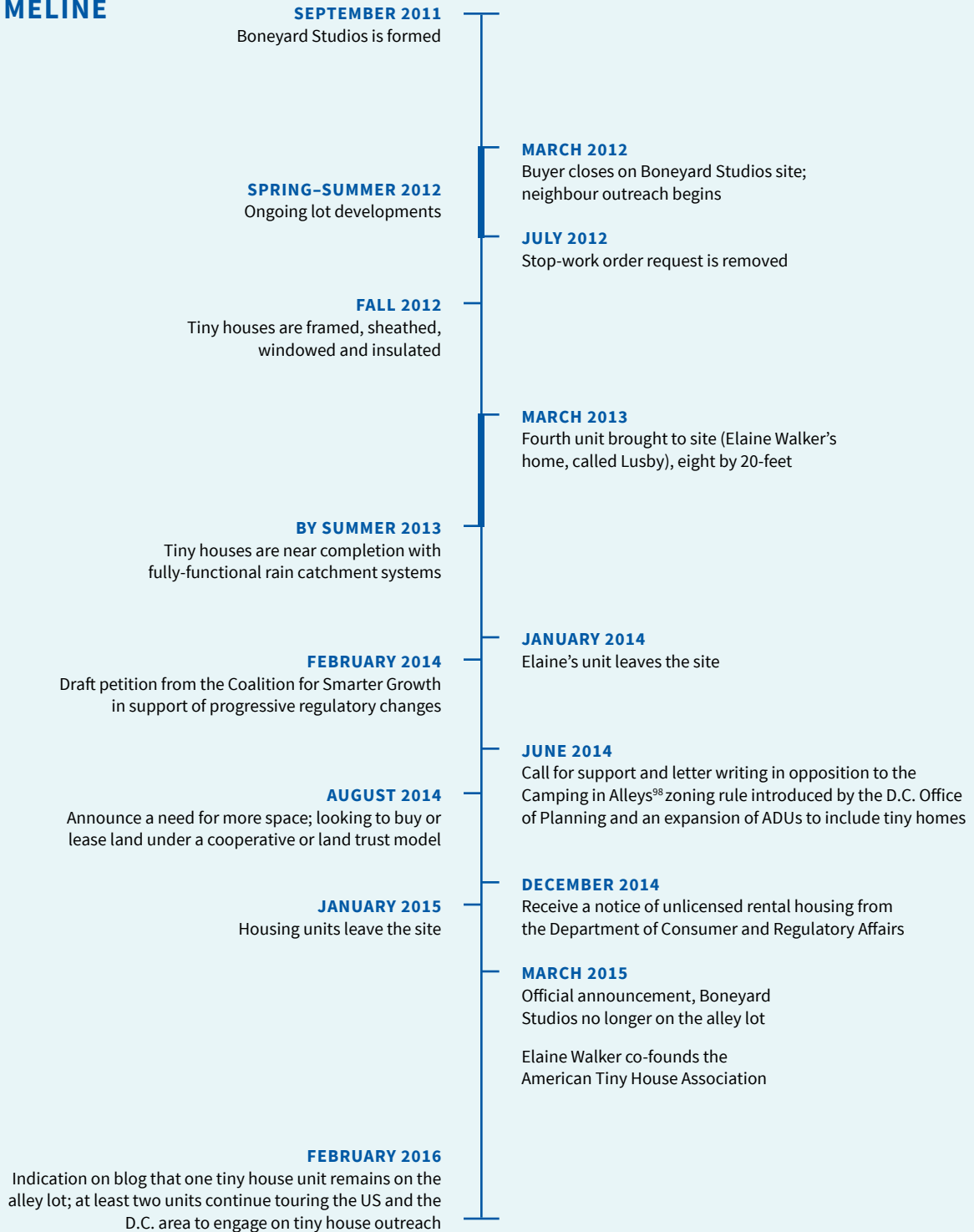

⁹⁸ Excerpt from Section 1609.2/1005/2 of the Zoning Code: "No camp or any temporary place of abode in any tent, wagon, van, automobile, truck, or trailer of any description shall be permitted on an alley lot unless approved as a special exception subject to the following conditions: (1) The use shall be located so that it is not likely to become objectionable to adjoining and nearby property because of noise, traffic, parking, lighting, sanitation, or otherwise objectionable conditions; (2) open fires shall not be permitted; and (3) the use shall not be approved for more than two consecutive weeks and no more than one month per calendar year." See boneyardstudios.org/2014/07/24/open-letter-to-dc-zoningplanning-on-proposed-cia-camping-in-alleys-and-adu-rule/

Vacant lot potential

Organizations are popping up all over the US encouraging residents to explore alternative uses for vacant lots. For instance, 596acres.org helps residents search for information about vacant lots in Queens, NY and provides a roadmap of how to organize and put the lots to use for the community. These often become gardens and urban farms. Made in the Lower East Side (MiLES), is an initiative that facilitates the transformation of vacant lots and storefronts in the Lower East Side by listening, co-creating, and prototyping the use of vacant spaces in collaboration with residents. See more at boneyardstudios.org.



Community gardening. Image credit: 596acres.org

Press on Boneyard Studios

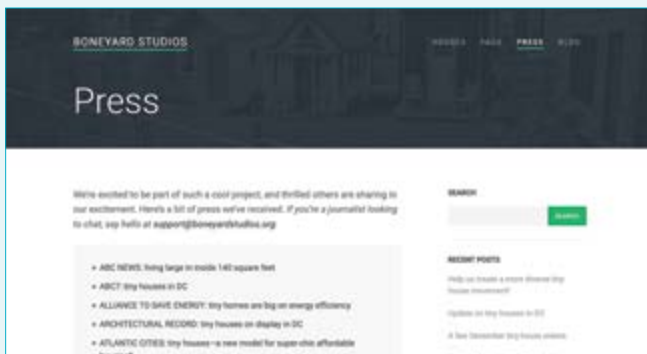

All press



NPR



dwell



Washington Post

BONEYARD STUDIOS PROS

- › **Engagement.** Boneyard Studios captured its project as it was unfolding through visual blog posts. As a result, they connected with diverse community partners, and established a space for local creators and innovators to take part in the greater vision. This also allowed them to share their tiny build experience and challenges. In 2013, the blog had over 600,000 web visitors. After the lot was purchased, the initiative rallied support by holding monthly open houses, various build events, and by reaching out to surrounding neighbours. The deputy mayor, council members, and other city staff also visited the show homes.
- › **Site development.** The property was fully fenced and outfitted with electricity, a community garden and a 946 litre cistern for watering.



Working together on the construction of the Pera house. Image credit: Boneyard Studios

BONEYARD STUDIOS CONS

- › **Lack of cohesion.** Blog posts allude to a divide between project team and a breakdown of project vision. (Whether this is true or not remains to be confirmed, as we weren't able to connect with the co-founders.)
- › **Regulation infractions.** Rental housing in D.C. requires a basic business license as per District law (D.C. Official Code 47-2828(a))⁹⁹. This applies to single-family and two-family dwellings, apartments, boarding houses and rooming homes. On December 8, 2014, the Department of Consumer and Regulatory Affairs sent site owners a letter stating that the property was supplying unlicensed rental housing.
- › **Sanitary issues.** Apparently, there were complaints regarding waste management. Two units used composting toilets, while another had an incinerating toilet for two years. It appears that D.C. has approved the use of composting toilets in container housing developments. However, it is unclear whether the units were required to be tied in to any municipal services (sewer).

- › **Servicing concerns.** The alley lot is without main street access and therefore, it was difficult to service from the front.
- › **Advocacy leads to more rules.** Since the showcase, D.C. adopted rules against full-time camping on alley lots. It is still uncommon to see tiny homes in the District; zoning is more flexible with accessory apartments and buildings, but not with dwelling units situated on alley lots.

Designing tiny in North Vancouver



The BC Tiny House Collective (BCTHC) worked alongside the City of North Vancouver to envision a tiny house community layout on a city-owned vacant lot in 2017.¹⁰⁰

⁹⁹ DC Official Code 47-2828(a); code.dccouncil.us/dc/council/code/sections/47-2828.html

¹⁰⁰“Designing tiny” BC Tiny House Collective; bctinyhousecollective.com/wp-content/uploads/2019/09/BCTHC_Designing-tiny_City-of-North-Vancouver-lookbook.pdf



DeAngelo Stewart and his tiny home in the Cass Community.

Image credit: Michael Nemeth, POLITICO Magazine (above); Michelle and Chris Gerard (below)

Case study no. 7: Detroit Tiny Homes | Detroit, MI

Cass Community Social Services (CCSS)—a non-profit based in Detroit, Michigan—provides programs around food, health, employment and housing. In 2016, it embarked on a permanent tiny house rent- to-own project called Detroit Tiny Homes. The goal was to create a community benefit agreement, in which the tiny dwellings would be built using local labour, to help tackle the city’s high unemployment rates. Once completed, the homes would increase their value over time and turn into valuable assets for their future owners.

Tenants are required to renew an annual lease for seven years. During this time, CCSS operates as the landlord. If the resident remains in the unit for the length of the contract, they will be deeded the property and home.

This project was 100 percent privately funded by corporations, foundations, religious organizations, schools and individuals through various fundraising campaigns. The first unit was open for public tours in September 2016.

casscommunity.org/tinyhomes/



CONTEXT

Detroit is a fascinating city, built around industry. To encourage and sustain future growth, development expanded outside of the urban core. However, an unexpected economic downturn and a decline in population, left areas with vacant land, highlighting the effects of urban sprawl. Despite these concerns, there is a resurgence amongst community minded residents, to make use of available land and take advantage of the fact that the city has no minimum square footage requirements. Vacant and under-utilized lots are being explored for future development, including a commercial strip with shops and amenities, that will provide employment opportunities.

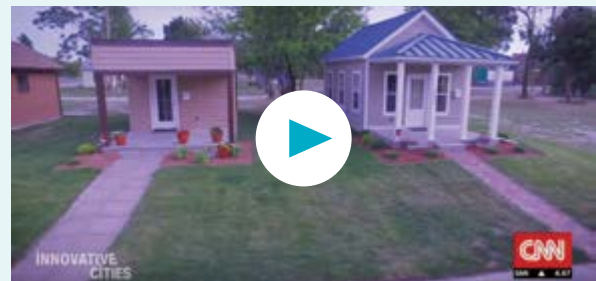

Video clip by CNN on *Detroit Tiny Homes*



Detroit tiny homes. Image credit: Michelle and Chris Gerard

Lot details

Location: Urban residential

Zoning: Residential

Neighbourhood: Low-income, predominantly African-American, close to amenities and transit

Lot cost: Less than \$1,000 USD

Lot size: 30 by 100 feet

Number of units: 25 units

On-site services: Municipal water, sewage and electricity; garbage pickup, recycling collection, road access, snow removal; each house has a solar array

Cost to service: \$6,800 per lot for municipal tie-ins to water, electric and sewage; separate meters

Utility costs: \$35 a month per resident; internet and phone services are covered by the resident

Shared amenities: None

Site developer/manager: CCSS

UNIT DETAILS

Tiny house type: Wood-framed tiny houses

Foundation type: Slab-on-grade

Unit sizes: 250 to 400 square feet

Features: Each house has a front porch, back deck or paved space. They are all fully furnished and equipped with appliances including a washer/dryer; tools are available for loan from an on-site warehouse

Cost to build: \$45,000 to \$65,000 USD

Builders: Trades professionals and volunteers under the supervision of a general contractor

Units built to date: 19 (25 units will be built as part of phase 1, and at least another 10 units and commercial buildings will be erected in phase 2)

Monthly rent: \$1 per square foot (to a maximum of \$400 per unit); includes water, taxes, insurance, security system, lawn and snow removal services

TENANCY

Requirements: Must meet low-income guidelines¹⁰¹ (annual income between \$7,000 and \$15,000), provide a damage deposit (one month's rent); and, in addition to paying rent, agree to participate in the program which includes monthly homeownership classes, financial coaching and volunteer time

Lease options: One-year term

Tenant demographics: Serving single women/men, people experiencing homelessness, or at-risk of homelessness; diverse residents including couples 20+ and older adults, college students and a few CCSS staff members

Number of people per unit: One to two

Other resources: Access to mental health counselling, education and health programs (all free); walking distance to food, medical clinic, community gardens and other amenities

¹⁰¹The US Department of Housing and Urban Development (HUD) defines low-income levels per county and state basis. Section 8 income limits for 2018 are: [huduser.gov/portal/datasets/il/il18/Section8-IncomeLimits-FY18.pdf](https://www.huduser.gov/portal/datasets/il/il18/Section8-IncomeLimits-FY18.pdf)

DETROIT TINY HOMES, TELL ALL

CCSS published a book, *Tiny Homes in a Big City*, outlining its project in more detail. It is available for purchase:

cass-community-publishing-house.myshopify.com

Lesson learned

- › **Do your research first.** Meet with the zoning authority before developing your business plan. This project didn't have many challenges working against it. Certificates of occupancy were required, however all necessary permits were issued within two months. The homes were also built to meet all local and state building codes.
- › **Engagement is key.** Meet with key stakeholders early on as it helps build community support.
- › **Media, media, media.** Traditional and social media platforms were incredibly effective at sharing key messages. The CCSS video showcasing the project received over 5 million hits in the first 24 hours of its release. The project received some negative comments on Facebook; CCSS responded by writing a book outlining the project in more detail for those unfamiliar with its goals.
- › **Phases are best.** Consider building out in stages. The process requires a steep learning curve.
- › **Good design will serve you well.** Build homes that are energy efficient and attractive. It will help mitigate negative feedback from the neighbourhood, and give residents a sense of pride in their home.



Eco friendly tiny houses in Nijkerk, Netherlands



Dignity Village, Portland, Oregon. Image credit: Dignity Village

Case study no. 8:

Temporary and permanent tiny house communities for people experiencing homelessness and/or low-income populations in various communities across the USA

In response to the housing crisis, many cities and counties in the United States have declared a state of emergency. This has opened the door to relaxed regulations and an exploration of alternative options to house vulnerable or at-risk populations, such as those with chronic disabilities, those experiencing homelessness and low-income earners.¹⁰²

Below are six examples of temporary tiny house communities designed to house those formerly living in tent encampments, as well as more permanent intentional villages. Case studies feature various communities across the US: Austin, Seattle, Olympia, Seattle, Eugene, Portland and Denver.

All these cities have used various forms of tiny houses in their projects. Each development is unique in terms of its location, model, funding and partnership structures, user profiles, successes and challenges. Here is what they had to share:

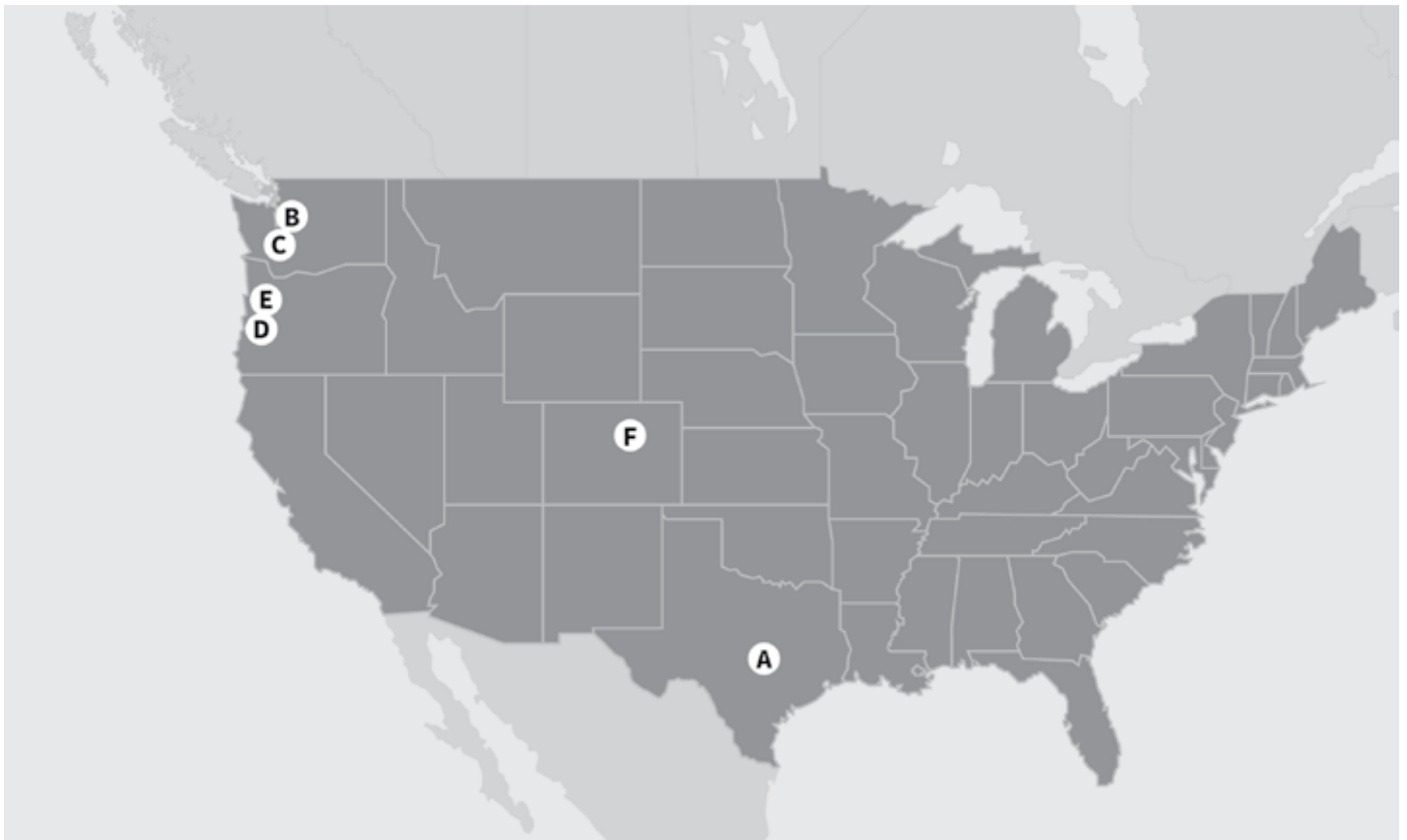

¹⁰²“Ending Homelessness for People Living in Encampments: Advancing the Dialogue.”

US Interagency Council on Homelessness; usich.gov/tools-for-action/ending-homelessness-for-people-in-encampments

A. COMMUNITY FIRST! VILLAGE | AUSTIN, TX

Located in Central Texas. A multi-phase, and 10-year planned community that provides affordable permanent housing and supportive community services for people with disabilities and those experiencing homelessness¹⁰³ through a master-planned tiny house community and RV park.

mlf.org/community-first/



Organization: Mobile Loaves & Fishes (MLF)

Location: Austin, Texas

Zoning: N/A (in Texas, land outside the municipal boundary is not zoned; since the village is not within Austin City limits, it is not restricted by zoning regulations).

This community will include four phases. Phase I includes a 27-acre master-planned community. Phase II broke ground in the fall of 2018 and consisted of a 24-acre expansion (totalling 51 acres) with 310 homes (210 tiny houses and 100 RVs), to be built over a three to four-year period. Mobile Loaves & Fishes is looking to raise \$60 million dollars through a capital campaign for the remaining phases. Note, the last two phases (III and IV) have yet to be planned.

Community First! Village launched a design competition in partnership with the American Institute of Architects (AIA) in Austin; 54 designs were submitted and four winners announced.

tinyvictories.org

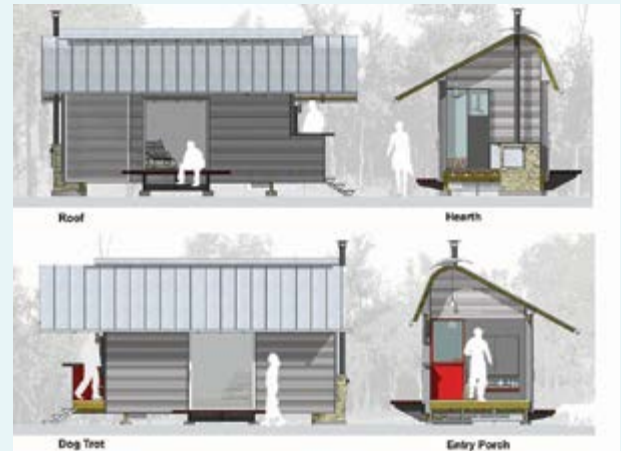

Casa Pequeña. Image credit: Michael Smith, AIA & Mick Kennedy, AIA of Texas

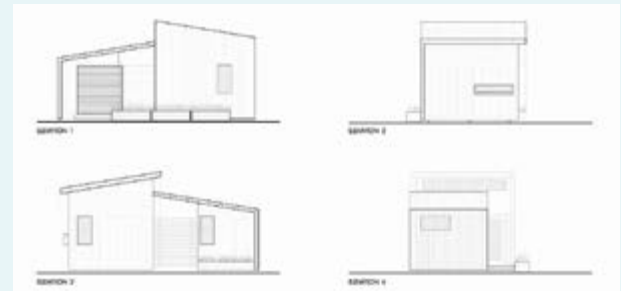

Dogtrot. Image credit: Becky Jeanes, Tray Toungate, Laura Shipley and Brianna Nixon of Designtrait



The Rooftop Hospitality House. Image credit: Cody Gatlin of Fazio Architects

¹⁰³The US Department of Housing and Urban Development (HUD) defines low-income levels per county and state basis. Section 8 income limits for 2018 are: huduser.gov/portal/datasets/il/il18/Section8-IncomeLimits-FY18.pdf. As per this document, HUD considers someone homeless if a person has been without a home for a year or longer, or for a period that adds up to a year

“Historically in the US, we’ve looked to the government to solve homelessness. We’re trying to change the paradigm; stereotypes can go away completely through storytelling and community. Housing will never solve homelessness, but community will.”

—Amber Fogarty, President and Chief Goodness Officer,
Mobile Loaves & Fishes



Promo video: youtube.com/watch?v=27XDnHnzdck

Lot size: 51 acres (phases I and II)

Units on site: Permanent tiny homes (or micro homes as they call them) on concrete foundations and RVs¹⁰⁴

Number of units: 125 micro homes and 100 RVs (August 2018)

Servicing: Micro homes have electricity but no plumbing; RVs are connected to water, sewage and electricity

On-site amenities: Five outdoor kitchens, laundry/restroom and shower facilities for tiny homes; community garden plot, bed and breakfast room for overnight visits, wifi, community market, outdoor movie theatre, outpatient medical centre, workshop spaces, study and fellowship area, a memorial garden and prayer labyrinth

Demographics: Serves 220 people; 85% retention rate since October 2015

Cost to rent: \$225 to \$375 for tiny homes; \$430 for RV

Timeline: October 2015, when residents (or *neighbours* as MLF calls them) first moved in

Funding: 100% privately funded; \$18.5 million was gifted or donated for phase I (took approximately two years to raise funds)

Partners: Various; no government assistance

Lessons learned

- › **Act on the needs of your community.** Working with people experiencing homelessness and vulnerable populations for years, MLF heard time and time again about the lack of community support available when considering the needs of those who experience chronic homelessness. This greatly influenced the design and concept behind the Community First! Village.
- › **Involve the community with the village.** Over 200 volunteers dedicated their time and resources to the project every week. In 2017 alone, more than 10,000 individuals came to the village to lend a helping hand, or to attend weekly outdoor movie screenings (offered year-round) or the Village of Lights, a free on-site annual Christmas-themed event. Connecting with the community is imperative to gaining their support.
- › **Partnership is the name of the game.** MLF had existing relationships with real estate developers, architects, builders, schools and corporate donors. These connections greatly impacted the success of the project.

¹⁰⁴Initially, MLF purchased used RVs; now, its RVs are custom-built. Each costs \$29,000 USD and is 350 to 375 square feet in size.

B. OTHELLO VILLAGE | SEATTLE, WA

A tiny home village that was built to replace a temporary homeless encampment and transition people into proper shelter. The site offered structured case management services. This model was derived from community opportunity and need, and functions through Temporary Use Permits that must be renewed annually.

lihi.org/tiny-houses



Painting the homes. Image credit: Low Income Housing Institute

Organization: Low Income Housing Institute (LIHI)

Location: Seattle, Washington, along major roadway

Zoning: Multi-family, commercial and neighbourhood commercial

“We are in a state of emergency. The community has shown us that it can build them [tiny homes] and put them up fast, so we are taking advantage of this momentum.”

—Lisa Gustaveson, *Planning and Development Specialist II*,
City of Seattle

Context: Seattle, Washington

There is a lack of shelter space and affordable housing. In 2017, 133 deaths as a result of homelessness were recorded.

The State of Washington, through the Engrossed Substitute House Bill (ESHB) 1956, authorizes religious organizations to manage temporary housing encampments, for those experiencing homelessness, on property owned or controlled by a religious organization. On March 30, 2015, a new ordinance was passed, allowing three villages (of up to 100 residents each) to operate on public or private land without a church host.

Lot size: 12,000 square feet (due to size, needed to pass an environmental assessment as outlined in the state Environmental Policy Act)

Units on site: 8 by 12-foot tiny homes on pier blocks; equipped with outlet, overhead light, and furnished with a space heater, mattress, bedframe and chair¹⁰⁵; the City of Seattle refers to these units as “sleeping structures”¹⁰⁶

Number of units: 38 tiny homes and nine tents (July 2018); each unit cost \$2,200 to build

Servicing: Electricity only; units are not plumbed

On-site amenities: Common area (includes kitchen and dining room), case management services (Monday through Friday, 9 am–5 pm), shower trailer (with three stalls)

Demographics: 60% men; all ages, all genders welcome, families with children are prioritized; some homes include space for up to four people

Cost to rent: \$0

Othello Village: Investment costs per year¹⁰⁷

Cost per person to the City of Seattle: \$1,711

Cost per person who leaves the program: \$2,310

Cost per person who leaves the program into permanent housing in 2016: \$8,888 (\$6,584

City of Seattle’s contribution)

Timeline: Opened in March 2016 (six months to develop)

Funding: 50% city investment (city funds expire after two years); LIHI fundraised the remainder through private donors (land was pre-owned by LIHI); setup costs was \$130,000 USD

Partners: City of Seattle, LIHI (case management)¹⁰⁸

Other: A transitional encampment for interim use requires a [Type I Master Use Permit](#)¹⁰⁹; (it took six months to obtain all permits)



For full tiny house designs and build instructions, see lihiwa.files.wordpress.com/2018/04/tiny-house-building-assembly-instructions-most-up-to-date.pdf

The BLOCK project

The City of Seattle is reinterpreting a City of Portland and Multnomah County Idea Lab model called *Place for You*¹¹⁰ whereby tiny homes on concrete foundations serve as accessory dwellings to shelter unhoused families in partnership with existing homeowners. Seattle’s version, called BLOCK project, offers 125 square foot off-grid units with a kitchen, bathroom, sleeping area, solar panels, greywater systems and composting toilets. See details at the-block-project.org/



See [promo video](#)

¹⁰⁵Units were built by various pre-apprenticeship programs, such as the Tulalip Tribe TERO program, Apprenticeship and Non-Traditional Employment for Women, Seattle VOICI Institute and the Carpenter Union apprentices

¹⁰⁶“Sleeping structures” are less than 120 square feet and are insulated, with windows, a door and lock. They have built-in storage and a bunk, and are hooked up to electricity. They are not outfitted with a kitchen and plumbing (no water). Sleeping structures are moveable but the City of Seattle has not discussed putting them on wheels [Lisa Gustaveson, City of Seattle, 2018]

¹⁰⁷“Homelessness Response”. City of Seattle; seattle.gov/homelessness

¹⁰⁸Nickelsville was its former operating partner

¹⁰⁹“Type I Master Permit”. City of Seattle; seattle.gov/dpd/permits/permittypes/mupoverview

¹¹⁰“Place for You”. Multnomah County; multco.us/dchs/a-place-for-you | enhabit.org/adus/wrapping-up-a-place-for-you-adu-pilot/

Lesson learned

- › **Before you start, engage.** Before launching a village, LIHI invites city officials and community members to attend stakeholder engagements, to have their questions and concerns addressed. This aligns with the Type I Master Use Permit requirements. Community outreach is mandated, and at least one public meeting in the proposed neighbourhood must occur at least 14 days prior to applying for a permit.
- › **Use your community to engage with community.** Meaningful participation helps shift negative perceptions. LIHI also has a community advisory council which connects with neighbours. It's vital to understand the wants, needs and concerns of those around you, early on. Invite future tiny house residents to speak at press conferences to share their stories, promote empathy and provide a platform for people who often feel their voices are not heard, to share their experiences.
- › **Get organized.** The model for this type of development grew faster than cities could amend land use zoning. Be sure to have political support early on. This includes human resources, permitting, elected officials (mayor, council), non-profits, donors and partners.
- › **Partner up.** Leverage the wave of media coverage and visibility around tiny homes and those who are building them. Be open to connect with others working on similar initiatives and collaborate to raise awareness.
- › **Volunteerism builds support.** Hundreds of volunteers—pre-apprentices, church groups, construction companies, non-profits—helped to build and paint the homes, and prepare the site for occupancy. These efforts increased support of the village from neighbouring communities.
- › **Communicate your wins.** Othello Village has a community advisory council to act as a liaison between the village and the community. The council shared community feedback with city officials and was granted an extension to occupy the space, until late 2019 when the land was more permanently developed.

The City of Seattle is currently exploring the use of vacant and under-used, city-owned lots. A few factors the city needs to consider when determining if a plot of land is suitable for a future village are:

- › Is it easy to service and environmentally sound?
- › Are there ordinances restricting use?
- › Is it on waterfront property or in a residential area?
- › Is the lot in close proximity to transit? (one kilometer)
- › Is the neighbourhood affected by high crime rates?

“One of the biggest challenges is finding land, and fast, and that does not need to be prepped for units that are temporary.”

—Lisa Gustaveson, *Planning and Development Specialist II*,
City of Seattle

Tiny House Villages: One Part of the City's Emergency Strategy (September 2019 update)

“The unsheltered crisis presents many challenges to the region's homelessness response system. Traditional programs and shelters remain a critical frontline resource for the thousands of vulnerable people living unsheltered. However, the City of Seattle continues to explore innovative programs that can meet the complex needs of some of the hardest-to-serve populations.” For more on this piece and the city's homeless initiatives, see updates for Othello Village, Camp Second Chance, and Georgetown Village¹¹¹ and, the Homelessness Response Blog for general information.¹¹²

¹¹¹“Updates for Othello Village, Camp Second Chance, and Georgetown Village”. 2019. *City of Seattle*; homelessness.seattle.gov/updates-for-othello-village-camp-second-chance-and-georgetown-village/

¹¹²“Homelessness Response Blog for general information”. *City of Seattle*; homelessness.seattle.gov/

C. QUIXOTE VILLAGE | OLYMPIA, WA

A former transient tent city turned self-governed permanent supportive housing for adults experiencing chronic homelessness, using tiny homes.¹¹³

quixotecommunities.org/



A tiny house in the village. Image credit: Quixote Communities

Organization: Quixote Communities

Location: Olympia, Washington

Zoning: Light industrial area zoned for single-room occupancy

Up next

Quixote Communities is developing two additional villages for veterans in Orting and Shelton, Washington. Orting Veteran's Village is scheduled to open March 2021, and permits for Shelton will be submitted in early 2021.

“All units are permanent and comply with all building codes and include full electricity, heat, plumbing and wifi. Once our tenants move in, they are no longer homeless.”

—Jaycie Ostenberg, Executive Director, Quixote Village

¹¹³“Tiny House: A Permanent Supportive Housing Model, A White Paper.” *Community Frameworks*. March 2015: communityframeworks.org/wp-content/uploads/2019/02/Tiny-Homes-White-Paper-March-2015-reduced_size.pdf

Lot size: 2.17 acres

Units on site: Eight by 18-foot (144 square feet) units on concrete piers; each unit has a front-facing porch, is furnished and plumbed; parcels are roughly 250 square feet

Number of units: 30

Servicing: Tied into municipal services (water, sewage and electricity); one meter per lot

On-site amenities: Common areas, community garden, laundry, meeting rooms, outdoor space, parking (10 spots), storage, tool shed and close proximity to community centre (includes shared kitchen and showers, open 24-7); close to transit, community college, grocery stores, restaurants and gas station

Demographics: Ages 18+, singles, men and women chronically experiencing homelessness

Cost to rent: 30% of income, roughly \$0 to \$350 (on average \$200 to 250 a month); requires \$100 damage deposit (usually paid for by Coordinated Entry System or CAC); Quixote receives 25 project-based vouchers from the Housing Authority to subsidize rent; after one year residents qualify for a [Section 8](#) voucher¹¹⁴, that provides them the flexibility to move if desired

Maintenance: \$26,000 per year (maintenance budget only; requires annual fire inspection by housing authority and quarterly inspections for cleanliness)

Other: Full-time case manager and program manager on-site

Timeline: Tent city from 2007–2013, relocated 20 times over six years. The Quixote Village was developed in partnership with seven church associations, and opened to residents on December 24, 2013

Funding: \$3.056 million, public and private funding

Partners: Thurston County (owns land), Garner Miller (designer/architect, MSGS Architects), Community Frameworks (this non-profit developer applied for grants and helped navigate permitting process), State of Washington (Housing Trust Fund), Housing Authority of Thurston County, City of Olympia and individual donors

Other: An agreement to lease land from the county at \$1 per year until 2054, required an amendment to allow multiple units on a single lot, and to receive a Conditional Use Permit. Individual units were considered sleeping units rather than accessory dwelling units, and were required to meet [International Residential Code](#)¹¹⁵ standards; city council adopted zoning changes to allow the project to move ahead.



Talks about Quixote Village. Image credit: Quixote Communities



Watch [promo video](#)

¹¹⁴“Section 8. Housing Choice Fact Sheet”. US Department of Housing; [hud.gov/topics/housing_choice_voucher_program_section_8](https://www.hud.gov/topics/housing_choice_voucher_program_section_8)

¹¹⁵International Residential Code; [iccsafe.org/products-and-services/i-codes/2018-i-codes/irc/](https://www.iccsafe.org/products-and-services/i-codes/2018-i-codes/irc/)

Lesson learned

- › **Know the community you're serving.** Quixote Village was born out of a tent city, and through this, had demonstrated many years of advocacy and community building. It understands the resident's needs and are mindful not everyone will move on to more permanent housing—many are struggling with a mental illness and/or trauma.
- › **Engage early.** Quixote Village worked with the community for roughly a year, meeting with the mayor, council and county commissioners, in addition to holding stakeholder engagements in various counties.
- › **Not in my backyard.** The local business association sued the city in protest, claiming the village would increase crime rates and decrease land values; and also, because the land was zoned for industrial use. In response, one business closed. Ultimately, Quixote managed to win the law suit and the business association's support. There are now 30 extra sets of eyes monitoring the neighbourhood. As a result, crime and vandalism in the area decreased.
- › **Same but different.** The first time around there was a steep learning curve. The second development is equally as challenging, as it is being proposed in a smaller rural community where the permitting process is slower. Identify what steps you need to take, familiarize yourself with the project details, and how to set your project apart from the rest. Be sure to connect with the right stakeholders.
- › **Universal design.** Design housing units with accessibility in mind.
- › **Follow others.** Learn from peers and other organizations who are promoting the transition from self-organized tent cities to tiny house villages such as Tent City Urbanism¹¹⁶.
- › **Consider your needs.** Don't underestimate the number of parking stalls needed for staff, residents and guests. Ensure residents have access to a bathtub. Include commercial grade appliances, such as large fridges and dishwashers, in the shared kitchen.

Quixote recommends speaking with surrounding businesses directly, in addition to hosting stakeholder engagements and testifying at council meetings.

¹¹⁶Heben, Andrew. "Tent City Urbanism: From Self-organized Camps to Tiny House Villages"

D. EMERALD VILLAGE | EUGENE, OR

A self-managed, low income community of permanent tiny homes. The village offers residents stable, low-cost housing; bridging the gap between homelessness and conventional housing options. Tenants become members of a limited equity housing co-operative, where they share managerial and operating responsibilities. Ownership of the property is held in trust by SquareOne Villages (SOV) and then leased to the co-op. The project builds upon the success of Opportunity Village, which is a transitional micro-housing community developed by SOV in 2013.

squareonevillages.org/



Emerald Village. Image credit: SquareOne Villages



Tiny homes in Emerald Village. Image credit: SquareOne Villages



Watch the [promo video](#)

Organization: SquareOne Villages (SOV)

Location: Eugene, Oregon¹¹⁷

Zoning: Medium-density residential (R2)

¹¹⁷Emerald Village is at the north-end of Eugene's Whiteaker district, which is an older gentrified neighbourhood with an alternative art scene. The area is low-income but slowly changing. Emerald Village is also located a mile east of Opportunity Village, the first tiny house community developed by SquareOne Villages; Opportunity Village is a transitional micro-housing community (a blend of structures and tents) for singles and couples experiencing homelessness which opened which opened in May 2014. It was built in nine months and cost \$98,475 with \$112,000 donated in-kind materials

Tiny house designs: squareonevillages.org/design



Eugene Prototype. Image credit: Nir Pearlson Architect



Den. Image credit: Envelop Design Architecture + Interiors

Tiny house construction costs per unit for all 22 units in US dollars

	WITHOUT LAND (PER UNIT)	WITH LAND (PER UNIT)
In-kind donations	\$22,727	\$22,727
Total cost	\$64,272	\$77,272
Actual cost (minus in-kind)	\$41,545	\$54,545

The cities of Seattle and Eugene have far more temporary tiny house camps/communities than Portland. However, there are still many questions that are slowing down the process and uptake of more developments. Two main challenges are at play, community support (including political) and zoning. That said, these models connect with communities in ways traditional shelters haven't. The residents are part of the neighbourhood and benefit from a sense of belonging and care from those around them.

Lot size: One acre

Units on site: Tiny homes with concrete slab-on-grade foundation, 160 to 353 square feet; each unit is built to the Oregon Residential Specialty Code (the same guidelines used to build single-family dwellings in the state) and includes a full bath, kitchenette, insulation, heating, electricity and plumbing

Number of units: 22 (17 are completed and occupied; five are in construction as of July 2019)

Servicing: Tied into all municipal servicing (water, electricity and sewage); single electric meter for all 22 houses helps reduce capital costs and ongoing energy costs for residents

On-site amenities: Common house with laundry, a community kitchen for group meals, and a flexible use space for gatherings and everyday use; includes tool storage, bicycle parking, community gardens and outdoor gathering spaces

Demographics: Targets extremely low-income residents (30% are median income or under); broad range of residents: 50% are over 60 years old living on a small fixed-income; others are younger singles, couples or families

Cost to rent: Co-op members make monthly payments of \$200 to \$300 to the co-operative to cover utilities, maintenance, long-term reserves and all other operating costs. Each member also pays a membership fee of \$1,500—paid at a rate of \$50 per month—enabling them to create a modest asset that can be cashed out if, and when, they choose to leave

Timeline: Purchased land in 2015; site development began in June 2017; opened to residents December 2017

Funding: \$1.2 million from private fundraising, \$120,000 (system development charges and municipal servicing, paid by the City of Eugene), \$1,500 per home (utility and waste management, paid by SOV), plus over \$500,000 in-kind donations from architects, contractors and builders

Partners: City of Eugene, Oregon Community Foundation, Collins Foundation, and nearly 100 businesses and a thousand donors

Other: Land was purchased from a private owner in 2015 for \$281,000; property value increased to \$1.8 million (2018). SOV has secured a 20-year tax exemption on the site; SOV retains ownership of the property and leases it to a housing co-operative composed of low-income residents. The property, not household contents, is insured by Great American.

SquareOne Villages has lobbied the Oregon State Legislature to approve and adopt a series of new building codes. As a first step, it advocated and passed [HB 2737 Small Homes amendment](#)¹¹⁸ (Tiny House Bill) to establish standards for building tiny homes legally in Oregon. As of January 1, 2018, the [Oregon Reach Code](#) was amended to allow for legal sleeping lofts accessed by ladders. Most recently, the legislature adopted Small House Specialty Code based on Appendix Q Tiny Houses of the International Residential Code. Read here for more on the state's findings through this exploration: oregonlegislature.gov/lpro/Publications/Background-Brief-Tiny-Home-Regulation-2019.pdf¹¹⁹

Lessons learned

- › **Can't plan for everything.** Understand that each site comes with its own constraints and benefits. SquareOne conducted a traffic study, an additional cost, to justify an alternative route to enter parking off Railroad Boulevard rather than North Polk Street.
- › **Bring the community into the village.** Every Monday and the first Saturday of each month, the village offers resident-led tours of the grounds. It gives locals a sense of pride and an opportunity to demonstrate the success of the model with surrounding neighbours and visitors.
- › **Build up. SquareOne built incrementally.** First they constructed Opportunity Village, and then applied lessons learned to build Emerald Village. (SquareOne started a new project based on Emerald Village in the rural community of Cottage Grove. It contains 13 tiny homes and has received a grant of \$500,000 from Lane County to pay for infrastructure.)
- › **Build for everyone.** Apply universal design to all homes. Consider “visitability”: make the units accessible to all visitors, especially those with physical disabilities. Also consider building studio and one-bedroom apartments, to accommodate unsheltered singles and couples experiencing homelessness.
- › **More hands, wider focus.** The work is heavily dependent on volunteers. SquareOne operates with two full-time staff, who spend a fair amount of time communicating with others. To expand its resources, the organization has recently shifted their focus to providing consulting service.

¹¹⁸HB 2737 Small Homes amendment; oregonlegislature.gov/lpro/Publications/Background-Brief-Tiny-Home-Regulation-2018.pdf

¹¹⁹Oregon Reach Code; oregon.gov/bcd/codes-stand/Pages/index.aspx

E. DIGNITY VILLAGE | PORTLAND, OR

Dignity Village was the first tiny house community in the United States.¹²⁰ A former tent-city, it is now a city-sanctioned, membership-based tiny house campground. The community village is self-managed and self-governed. Its mission is to provide transitional housing to people experiencing homelessness.

dignityvillage.org



View of the homes at the village. Image credit: Dignity Village



Organization: Dignity Village (DV)

Location: Portland, Oregon

Zoning: Light industrial zone

Location, location, location

The site is on a fenced-in asphalt surface and is adjacent to the city's yard waste facilities, also called the Sunderland Yard. Residents have complained about respiratory issues, however no studies have been conducted to determine if the site's location has or can impact the health of those living in the village. Dignity Village is also next to the county jail and an athletic field, and is two miles away from the closest food store. There is, however, a bus line that stops right outside the community.

The City and Village

On February 26, 2004, the City of Portland permitted a portion of the Sunderland Yard as a designated campground under terms [ORS 446.265](#)¹²¹. This state statute allows six municipalities to designate up to two sites as campgrounds for transitional housing, for persons who lack permanent shelter and cannot be placed in other low-income housing. The statute notes that these campgrounds may be operated by private persons or non-profit organizations. On May 16, 2017, the city adopted [ordinance no. 180959](#)¹²², allowing Dignity Village to manage the transitional housing campground at Sunderland Yard. The village is in current talks with the City to extend its annual contract. As of 2018, the City of Portland still limits tiny homes to temporary housing encampments for people experiencing homelessness. According to one of its planners, here are the main challenges to moveable tiny homes from the city's perspective:

- › Is the house truly habitable?
- › Where to place them and in which zones?
- › How will they affect single-family neighbourhoods?
- › How will they be serviced?
- › What types of greywater filtration systems will they use?

¹²⁰Smock, Kristina. "An Evaluation of Dignity Village." *Oregon Live*; media.oregonlive.com/portland_impact/other/Dignity%20Village%20Evaluation%20Report%20Final%202003-22-10.pdf

¹²¹ ORS 446.265; oregonlaws.org/ors/446.265

¹²² Ordinance no. 180959; efiles.portlandoregon.gov/Record/2852084/File/Document/

Lot size: Over an acre (parcels are 360 square feet)

Units on site: 120 square foot tiny homes on concrete piers or wood posts (18-inches off the ground); housing units are not plumbed or tied into electricity; they are heated with propane space heaters and some homes have solar panels. (DV is working on networking the solar panels into one shared system that feeds back into the grid)

Number of units: 43

Servicing: Municipal servicing (water, electrical, sewage), as well as garbage pickup, recycling, road access and rainwater collection

On-site amenities: Common area (including basic kitchen, TV, sofas, one shower; open 24-7), four porta-potties, community garden, extra sleeping quarters, meeting rooms, outdoor space, parking (in a designated parking lot), tool shed

Demographics: Wide range, singles and couples over 30; individuals on the waitlist for subsidized housing, temporary and short-term workers; on average people are staying two to three years, some as long as 11 years

Cost to rent: \$35 per month plus 10 hours per week of volunteer work to off-set operational costs, includes all utilities except propane; balance is covered by micro business (residents sell scrap metal and firewood acquired through the city or Craigslist)

Timeline: Former tent city located under a bridge moved on-site in 2001; began construction in 2004; moved to another part of the site in May 2007, when the village was completed; from 2007 to 2010, tents were replaced with semi-permanent structures

Funding: City (land asset); Joint Office of Homeless Services (funds on-site support staff)

Partners: City of Portland (land, development and limited on-site support with housing, work searches and basic health support), Dignity Village, JOIN (assists with accessing social services)

“There are a lot of people doing a variation of this work. Make it fit into a box so people can understand your vision.”

—Katie Mays, Dignity Village Program Support Specialist, JOIN

Other: The City improved electrical service to the site in 2007, and installed sanitary and storm sewers, site drainage, potable water, fencing, concrete, moving of dirt berm, asphalt and paving, and waived all building development cost charges; liability insurance is provided by Great American; maintenance is done by an on-site building coordinator (resident position). During the winter months (November to March), the common areas serve as a community-wide homeless shelter. Guests can stay for up to three days and return after four-day intervals



A colourful home at the village. Image credit: Dignity Village



Closer look at a home in the village. Image credit: Dignity Village

Lessons learned

- › **Measure twice, build once.** In 2001, homes were built with reclaimed building materials that were not to code. In 2008/2009, another 18 structures were constructed over a weekend using stick frames and plywood; these houses are now experiencing issues with the insulation and have mould. Include building professionals throughout the design and build process, and perform quality construction.

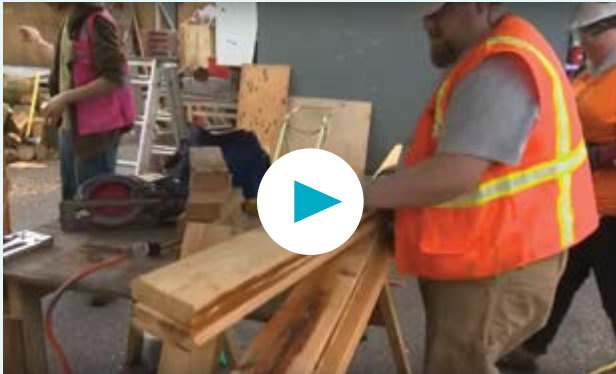

Watch video on new builds in 2018 and interviews with tenants: [youtube.com/watch?v=162lp3N-t0c](https://www.youtube.com/watch?v=162lp3N-t0c)

- › **Location.** The site is far out and close to a compost yard. But if it wasn't this site, there would not be a site. Lack of options may give the impression that housing the homeless is an afterthought.
- › **Let the experts do what they do best.** Let city staff handle permitting and then handover the project to the operators and partners to execute and manage.
- › **Maintaining status quo.** Consider the housing first approach when it comes to substance use. It demonstrates the need for case management when housing vulnerable populations struggling with addiction and mental illness.
- › **A shared vision.** Involve members of the village in all aspects: design, construction, outreach. It gives residents a unifying purpose and leads to more collaboration.
- › **Build a sustainable model.** Strike the right balance between self-governance, community ethos and autonomy. If possible, fundraise and purchase your own land and develop a more intentional community. A strong board of directors can collaborate with village members and residents to create a shared vision. Establish an advisory committee with the power to affect change.
- › **Rally support.** Build a broad coalition of supporters that can champion your cause in different ways. Find an ally at the city level and develop a strong justification for your request.

F. BELOVED COMMUNITY VILLAGE | DENVER, CO

Beloved was the first tiny house community for those experiencing homelessness in Denver. The village is self-governed and opened in July 2017. It provides small-scale tiny homes for up to 22 people (11 tiny homes), that began as a 180-day pilot project. Its mission is to create homes for people experiencing homelessness while cultivating community-living and self-empowerment.¹²³

coloradvillagecollaborative.org/



Image credit: JC Buck



Watch the promo video: facebook.com/RadianDenver/videos/beloved-community-village-a-tiny-home-village-for-the-homeless/1564914983566742/

Organization: Colorado Village Collaborative (CVC)

Location: Denver, Colorado in historic Globeville

Zoning: Urban industrial zone

Lot size: 14,000 square feet

Units on site: 96 square feet tiny houses on large concrete blocks, considered temporary foundations; units are fully permitted and inspected by the [International Building Code](#)¹²⁴ and the International Residential Code

Number units: 19 (February 2020)

Servicing: Municipal servicing (water, electrical, sewage), as well as garbage pickup, recycling and road access

On-site amenities: Common area with shared kitchen and bathroom facilities, laundry, meeting rooms, outdoor space and optional case management; Internet and phone (\$50 collectively per month for the entire village)

Demographics: Individuals that are experiencing homelessness or at-risk of homelessness, including people that often face barriers and issues accessing housing/shelter, couples, people with pets, people with disabilities, those that identify as LGBTQ, employed individuals

Cost to rent: \$0

Other: No damage deposit required; no lease or predetermined lengths of stay

¹²³“Colorado Village Collaborative’s Beloved Community Village Evaluation Findings.” *Barton Institute for Philanthropy and Social Enterprise. University of Denver.* July 16, 2018; bartoninstitute.org/tiny-homes

¹²⁴International Building Code; iccsafe.org/products-and-services/i-codes/2018-i-codes/ibc/

Timeline: Five months of planning, plus nine weeks of construction; opened to residents on July 21, 2017

Funding: \$145,000 for construction costs; various funders¹²⁵

Partners: City of Denver, Colorado Village Collaborative, Bayaud Enterprises (optional case management)

Other: In May 2019, Beloved Community Village relocated to a city owned site; due to permitting, the CVC has a one-year renewable license to operate for \$10 per year¹²⁶; property insurance is provided by General Liability Insurance; maintenance is done on an as needed basis by a part-time worker.



Construction at the village. Image credit: JC Buck

Lesson learned

- › **Know your codes.** Understand what you can and cannot do. Strict zoning and building regulations prevented the collaborative from delivering a variety of the units on site. It was also required to rezone the land from commercial/mixed-use to temporary unlisted use for 180 days, which took three months to secure.
- › **Would haves.** There was a lot of uncertainty in working with the city, considering the number of permits and the quality of the facilities in the common area. In retrospect, the Colorado Village Collaborative should have invested more in the bathrooms and the kitchen since they are the heart of the community.
- › **Connect with everyone.** The CVC engaged with the mayor's office, staff in the community planning and development departments and close neighbours. There were sceptics who believed the project wouldn't work and that the neighbourhood, wasn't the right fit.

However, data shows that nearly 80% of the surrounding residents interviewed reported no impact or a positive impact on traffic, safety and noise. See [bartoninstitute](#). Other key stakeholders were individuals experiencing homelessness, advocates, congregations, service providers and local neighbourhood organizations. The CVC provided presentations, and one-on-one meetings, as a means of connecting with the community. That said, the collaborative is working on a second project and is receiving a lot of push-back. Each project is different, but the challenges are similar: zoning regulations and public will.

- › **The focus.** Find ways to ensure the highest quality of life for all residents.

¹²⁵Project funders include: Barton Institute, the Denver Foundation, Gary Community Investments, Reva and David Logan Foundation, Buck Foundation, LivWell Cares, Whiting Turner Contracting Company, Denver Homeless Out Loud, Bayaud Enterprises, Catholic Worker, Interfaith Alliance of Colorado, Beloved Community Mennonite Church and individual donors

¹²⁶Colorado Village Collaborative: coloradvillagecollaborative.org/beloved-community-village



9 | Exploring BC city studies



Engaging the community at go, go TINY. Image credit: BC Tiny House Collective

Most tiny house case studies investigate projects that are in progress, have ended, were well executed or well-intended, but didn't achieve their vision. They give readers insight into the process, lessons learned and advice to others. It doesn't, however, showcase the many players that are equally enticed by tiny homes but not yet far along on their journey or future pathway forward. Better yet, it doesn't capture initial thought processes, challenges and ways to circumvent them and how tiny may not be for everyone.

For this reason, we approached four municipalities in British Columbia that demonstrated interest in tiny homes (moveable or fixed in place) as an alternative housing option, in response to our collective housing crisis. While some are in an "exploratory" stage, others are still on the fence as to whether tiny will work for them now or ever. These cities are Prince George, Nanaimo (includes a feature on Victoria), Tofino and Squamish.

Each case is unique and demonstrates the variety of lenses from which one can see tiny homes. Each community also speaks to its own city context and how tiny could work, if at all, given their land economics, political and public support, housing needs and residents' interests.

Note: Our lead contacts at the cities of Nanaimo, Tofino and Squamish answered a questionnaire and provided in-depth scope statements. This greatly informed their case studies, including project assumptions and municipal contexts. Please contact these municipalities directly for the most current information.



View of Prince George. Image credit: CPG1100; Creative Commons

City study no. 1:

City of Prince George, BC

In mid-2018, we reached out to urban planners at the City of Prince George to see whether they would like to take part in this project. What we heard was surprising. The city planning department is not seeing a push from the public to go tiny.



CONTEXT

Region: Central B.C.

Municipality: City of Prince George

Population: 65,510 (2016, census)

Vacancy rate (rental): 4% (2018, CMHC)

Average cost to buy a single-family home (3 bedrooms):
\$350,713 (2018)

Minimum unit size: None

Average age of the population: 39 (2016, census)

Average total income in 2015: \$47,219 (2016, census)

HOUSING IN PRINCE GEORGE

Compared to the coastal regions of B.C., Prince George is still relatively affordable. In 2018, the average price of a single-detached home was \$350,713 (BC Northern Real Estate)—an increase of \$31,546 (9%) over the previous year. In contrast the number of sales declined from 917 to 814. This shift is partly due to a growing interest to live in higher density housing, such as townhomes and condos. While the greatest growth appeared in multi-family homes, it was estimated that demand for single-family homes will remain flat in 2019 because of rising costs and financing challenges.¹²⁷



View of city from LC Gunn Park, Prince George. Image credit: CPG1100; Creative Commons

¹²⁷Nielsen, M. "Prices Rise, Sales Drop for Single-family Homes in Prince George." *Prince George Citizen*. January 10, 2019; princegeorgecitizen.com/news/local-news/prices-rise-sales-drop-for-single-family-homes-in-prince-george-1.23591530



Tiny house on wheels. Image credit: Borealis Tiny Homes



Heating and appliances inside a tiny house. Image credit: Nelson Tiny Homes

TINY IN COLDER CLIMATES

With real estate listings as low as \$89,900 for a 30 year-old 700 square foot condo (July 2019, [zolo.ca](#)), it does beg the question: is the demand for tiny prevalent everywhere or is it strongest around denser urban areas, where housing is exponentially unaffordable and unattainable? Whatever the case may be, if one could afford a single-family house would they still opt for a tiny one? This has more to do with personal choice than trends. We decided to reach out to two tiny house builders from Prince George and Nelson—Borealis Tiny Homes¹²⁸ and [Nelson Tiny Homes](#)¹²⁹ respectively—to better understand what variables to consider when choosing to build tiny in a colder climate. Here's what they had to share:

- › **Timing is everything.** The most favourable time of year to build in Prince George and Nelson is April to October. You can dig a foundation or install servicing in a tiny house in Nelson up until mid-November.
- › **Inside is best.** Cold weather requires a heated facility or shop; quality finishing work is best done inside.
- › **Beat the cold.** Sufficient insulation, quality doors, windows and plumbing incorporated into a raised floor are essentials and clever work-arounds when it comes to building in colder climates.
- › **Bigger investment.** Tiny houses are built to the environment in which they live. This implies an added material cost, especially as it relates to thermal performance in colder regions. The cost to transport these materials to Prince George or Nelson, or other cities outside major urban centres should also be considered. Material costs can be at least 30% higher than those outlined in Table 2 in Section 3 of this report.

SMALL DWELLINGS IN P.G.

The City of Prince George's zoning bylaw does not limit dwelling size; there is no maximum or minimum requirement. In February 2019, Faction Projects Inc. (on behalf of River City Ventures Inc.) applied for a site-specific zone. Planners proposed a form-based, site-specific zone called Z20 Patricia Residential that permits an apartment structure and restricts site coverage, setbacks and building height without limiting density. The application focused on student micro suites; it was approved by council and will be situated in the C1 Downtown Commercial Zone. The development will deliver the highest density in the city, around 575 dwellings per hectare; currently the C1 zone allows up to 280 dwellings per hectare. Based on this increase, parking will be reduced to 0.5 stalls per dwelling. This example greatly demonstrates the rise of higher density small forms across B.C., including Prince George.¹²⁹ For more on this project, benefits to the community and its regulatory analysis, see princegeorge.ca/Business%20and%20Development/Pages/Housing/InfillHousing.aspx

¹²⁸Please note, as of 2019, this company is no longer operational

¹²⁹Nelson Tiny Homes; nelsontinyhouses.com/



City of Nanaimo. Image credit: CMT Group 1 Inc. and Garmin International, Inc. / marianas.com

City study No. 2: City of Nanaimo and City of Victoria, BC

The City of Nanaimo adopted an [affordable housing strategy](#)¹³⁰ in September 2018. This guiding document outlines the policies the city will implement with the aim of diversifying its housing stock, including expanding its secondary suite¹³¹ policy, and incentivizing multiple and smaller units. As part of the latter objective, the strategy calls for a review of local bylaws and regulations to identify barriers to alternative housing forms, including tiny homes. The strategy also contemplates support for a local demonstration project (see Nanaimo Affordable Housing Strategy, Section 2.3f). This objective was proposed as a medium-term priority that would be reviewed in the next three to five years. The key measure of its success will include the number of lock-off, micro-suites or tiny homes created as a result (see strategy, pages 36 and 38).



CONTEXT

Region: Vancouver Island

Municipality: City of Nanaimo

Population: 90,505 (2016, census)

Vacancy rate (rental): 2.2% (2019, CMHC)

Average cost to buy a single-family home (3 bedrooms):
\$580,330 (June 2019, City of Nanaimo)

Minimum unit size: None

Average age of the population: 44.2 (2016, census)

Average total income in 2015: \$40,502 (2016, census)

There are many housing priorities that require strategic implementation that are competing against tiny homes on permanent foundations. For instance, the demand for affordable multi-unit buildings. This has prevented the city from addressing portions of the building code that remain barriers to permitting tiny homes on wheels.

While there is support for the development of a wide range of diverse housing options, there are also concerns that tiny home villages may not be an affordable option, or the best use of valuable urban land, given their relative low density. This is particularly a concern when tiny homes are clustered together rather than built as infill housing.

¹³⁰“Nanaimo Affordable Housing Strategy”. *City of Nanaimo*; nanaimo.ca/docs/default-document-library/nanaimoaffordablehousingstrategyfinal.pdf/

¹³¹To clarify: *Secondary suites*, as outlined within the City of Nanaimo’s zoning bylaw, include both accessory dwellings (ADUs) and in-house secondary suites. An ADU, also known as a carriage house, is a detached unit typically in the backyard of the primary residence on a single-family residential lot; whereby an in-house secondary suite (or just a *secondary suite*) is a housing unit within the main home such as a basement or attic suite. For the sake of this case study, “secondary suites” within the main house will be referred to as “in-home secondary suites.”

NANAIMO AND HOUSING AFFORDABILITY

The City of Nanaimo continues to encourage secondary suites in all new single-family dwellings and is taking steps to expand its coach house program. Nanaimo was one of the first cities in B.C. to introduce in-house secondary suites, starting in 2005. There are no development cost charges or minimum size requirements in the zoning bylaw for ADUs in Nanaimo.

That said, the vast majority of secondary suites created have been within the primary dwelling.

“Every community is unique and needs to decide what measures it wants to adopt based on local priorities and political direction.”

—*On recommendations for industry and other cities to allow tiny homes, by Karin Kronstal, Social Planner, City of Nanaimo*

Part of the issue is where suites are allowed. Most lots can have either an in-home secondary suite or a laneway home but not both. The Nanaimo Affordable Housing Strategy proposes revising regulations to allow three dwelling units on an existing single-detached lot where additional density can be accommodated (for example, a house on a corner lot, with an in-home secondary suite and a laneway house, or on lots with lane access). Other aspects of the policy update include revisions to the zoning bylaw to differentiate in-home secondary suites from laneway houses, and developing specific policy and regulations to support the development of laneway houses on laneways in all standard single-detached lots that are less than 800 m².

With these policy updates, the city believes it will encourage the construction of more laneway homes. This exploration would further align with its strategy and may increase uptake by encouraging smaller more affordable tiny houses—prefabricated or stick-builds on a foundation—on smaller lots (beyond those with laneway or corner access).

CITY OF VICTORIA AND TINY HOMES

Further along in its tiny exploration, and leading the momentum on Vancouver Island, is the City of Victoria.

As outlined in its 2019–2022 Strategic Plan, one of its 25 key actions for staff in the first year is to “allow moveable tiny homes in all backyards that currently allow garden suites at rents of no more than \$500 per month”, and “allow tiny homes and garden suites on lots that already have secondary suites or duplexes.”¹³² Since the adoption of the strategic plan, the city has approved an update to its housing strategy (Victoria Housing Strategy 2016-2025 Phase Two 2019–2022¹³³), which has incorporated all housing actions, including tiny homes. The housing strategy prioritizes larger-scale housing actions and positions the work on tiny homes later in phase two.

In March 2019, the City of Victoria held a housing summit. Over 150 delegates attended from all sectors—academia, non-profit housing, government, community land use and development. One of the nine concurrent sessions was on tiny houses. The mayor and council are keen to see this building form used as rental units in single-family neighbourhoods. However, they see these main challenges:

- › **Zoning:** Where can they be situated and what are the best ways to address a neighbour’s concerns?
- › **Codes:** How to verify these structures are built safe and code compliant?
- › **Support:** Tiny houses have gained political support, but what about community endorsement?
- › **Tenancy:** How do tiny homes fit in with the Residential Tenancy Act? Whose responsibility is property and building maintenance? What about dispute resolution? And who’s liable if the tiny house is used as an ADU, the landlord and/or the tiny homeowner?

Going forward

Victoria will need to strategize on next best course of action. There are some options to consider. Although tiny houses do not meet BC Building Code requirements, the planning department could create an alternative bylaw to control

¹³²“2019–2022 Strategic Plan.” City of Victoria. March 14, 2019; victoria.ca/EN/main/city/strategic-plan.html

¹³³“Victoria Housing Strategy 2016-2025 Phase Two 2019–2022”. *City of Victoria*; victoria.ca/housing

liability and safety. This may be a bit challenging given that the BC Building Code outlines the minimum safety standards for fire egress, stair safety, ventilation, insulation and several other building requirements that these homes do not comply with. In order to bypass these standards, the city needs to consider all possible consequences. Secondly, Victoria and other municipalities could advocate for a separate tiny house standard, an amendment to the BCBC and a review of the [Residential Tenancy Act](#)¹³⁴.

Tiny homes and the Residential Tenancy Act

For this report, the Residential Tenancy Branch was contacted to see whether mobile tiny homes or small modular units under 500 square feet are recognized and are covered under the Act. They advised us to seek independent legal counsel on this matter. Further research is necessary to better understand municipal, landlord, owner and tenant rights as they pertain to tiny homes.

The City of Victoria has its own barriers to address. Most properties do not have laneway access.

This limits the type of units that can be placed on each lot and restricts access to municipal services. Each municipality will need to explore options to manage alternative greywater filtration systems and how to permit composting toilets, before they determine if tiny houses will be recognized as a type of ADU.

The city is looking to address these issues through consultation and community feedback. They also hosted two public open houses in April 2019 to discuss housing strategies, priorities, objectives and areas that need further exploration.

In terms of next steps, the city is looking to launch its exploratory review as part of its housing strategy phase two implementation. This will include a research and analysis phase, followed by extensive engagement with key stakeholders, industry and the public. The process will rely heavily on provincial and federal governments coming to the table. That said, planners anticipate the first round will take a minimum of six months.

“We keep hearing this time and time again:
Why are these homes not legal?”

—Marian McCoy, Volunteer, *Tiny House Advocates of Vancouver Island*

Victoria’s tiny house survey

In July 2018, the Tiny House Advocates of Vancouver Island (THAVI) met with the City of Victoria’s mayor and planning staff to recommend tiny house rentals as an alternative to conventional garden suites with rents capped at \$500 a month. THAVI predicts some communities will reject tiny homes, and that there will be challenges with the Residential Tenancy Act. One way to counter this is through community engagement and education, for instance, exploring what is a moveable tiny home, its systems (on and off-grid waste management) and who will use it. Currently, there is a misconception that tiny homes are only for those experiencing homelessness or low-income. However, the biggest demographic in Victoria is single women in their 50s who are empty nesters or those without partners.



¹³⁴ Residential Tenancy Act; bclaws.ca/civix/document/id/complete/statreg/02078_01



A garden suite in Victoria. Image credit: City of Victoria

“We are looking at tiny homes from a perspective of ‘how can we do this’ rather than why we can’t. Still, there are several different steps to take and we won’t know them all until we create a project plan.”

—Lindsay Milburn, Senior Planner, Housing Strategy, City of Victoria

Lessons learned

Bring the right people to the table. The City of Victoria has only done tentative exploration through an education session (with a tiny house advocate group) and a workshop at its housing summit. At the session, city staff were not able to come to an agreement as to the best course of action. However, it was extremely helpful having policymakers and informed/educated advocates in the same room.



City of Victoria Summit, March 2019. Image credit: City of Victoria



City study no. 3: District of Tofino, BC

The District of Tofino is experiencing a shortage in available, attainable housing options for its seasonal workers and residents. A pilot project is proposed to further incentivize rental housing by allowing a third dwelling unit (tertiary units) on each lot. This would give property owners the ability to house more people on a single lot, while avoiding the Tofino-wide ban (which the district has no plans to enforce) on short-term rentals. Ideally, allowing tertiary dwellings would not require rezoning. Any necessary zoning amendments, related to the proposed policy, would be completed by the District of Tofino to make the program easily accessible and encourage landowners to adopt the program. Section 219 covenants or home agreements have been helpful in advancing certain housing developments, such as those providing affordable housing, but would likely not apply to tertiary dwelling units. (Note: Short-term rentals are regulated through a business license and bylaw officer.)



CONTEXT

Region: Vancouver Island

Municipality: District of Tofino

Population: 1932 (2016, census)

Vacancy rate (rental): Average 4.5 units month (2013-2014)
tofino.civicweb.net/document/45838

Average cost to buy a single-family home (3 bedrooms):
\$599,000 (2016, *Canadian Real Estate Magazine*)

Minimum unit size: None

Average age of the population: 38.3 (2016, census)

Average total income in 2015: \$40,697 (2016, census)

HOUSING IN TOFINO

Currently, the district allows detached ADUs and secondary suites (units in the main house). The laneway house program was first launched in 1997 and was expanded in 2011. In total, 24 units have been built to date (July 2019). The structures cannot exceed 750 square feet in size. Currently, Tofino does not allow ADUs and secondary suites on the same lot.

Through this potential pilot project, Tofino hopes to explore the use of small housing as the third dwelling with foundations and identify servicing options that are compliant with the BC Building Code, and existing bylaw requirements. Tiny houses on wheels could be part of a future phase, if a CSA standard is created that certifies this form as a dwelling unit, and if this standard is recognized by the BC Building Code.

At present, local governments can introduce tiny homes within their communities via two routes: council-approved rezoning (bylaw change) or a resolution via a Temporary Use Permit (TUP) as pursuant to Section 493 of the [Local Government Act](#)¹³⁵ and municipal bylaws. (However, a special zone or TUP is not always required; tiny homes on wheels may be permitted if an area is already zoned for campground use.)

TOFINO AND TEMPORARY-USE PERMITS

Two lots in Tofino have been issued TUPs, one in 2015 and the other in 2018 (with a third under review in 2019) to provide rental accommodation for staff, both long-term and seasonal. The Mackenzie Beach Resort¹³⁶, applied in June 2018 under this permit type to operate a campground for a period of three years in a tourism commercial and small holdings district (CS and A1). The housing consists of 20 recreational vehicles for up to 50 residents and is equipped with water, sanitary and electrical municipal hookups, with each RV being self-contained with its own washroom. The campground also includes an on-site manager, access to the Mackenzie Beach Resort washroom, shower and laundry facilities, and access off Mackenzie Beach Road. Under Section 497 of the Local Government Act, TUPs can be issued for a maximum of three years and renewed once for an additional three years. The applicant reported the campground offered “affordable rental and affordable ownership solutions for people living and working in Tofino” as outlined in [Tofino’s Official Community Plan](#)¹³⁷ (see 3.3.3.4.6.). The units were intended to be rented at \$900 each per month, with full hookups.



Image credit: Olivier Lévy; Creative Commons

¹³⁵Section 493 of the Local Government Act; [bclaws.ca/civix/document/id/complete/statreg/r15001_00](https://www.bclaws.ca/civix/document/id/complete/statreg/r15001_00)

¹³⁶ “District of Tofino Regular Council Meeting”. Council Chamber, *City of Tofino*. June 26, 2018; tofino.civicweb.net/filepro/documents/75502?preview=81332

¹³⁷Tofino’s Official Community Plan; tofino.ca/official-community-plan

Qualified tenants were defined as someone living and working in Tofino with a minimum stay of one month or more.

While these permits may open the door to temporary alternatives, they avoid community amenity and infrastructure contributions, and are exempt from development cost charges. As such, the district is moving towards more permanent solutions that are inherently better controlled, organized and deliver a higher quality of housing.

NEXT TINY STEPS

If tiny houses on wheels are introduced into Tofino, a new land use (zoning) designation is unlikely as long as they are not code-compliant. And while council and staff are in favour of the form, there are a few technical concerns to consider.

- › Would an engineer need to sign-off on land use specific to tiny houses (in addition to the built form)? And could this circumvent meeting the minimum requirements outlined in the BC Building Code?
- › If a new zoning district were established, would it be designated as a C6 Campground Commercial District or a C7 Destination Campground District?
- › What servicing, transportation, parking and security requirements would these developments need?
- › Will there be any constraints to issuing occupancy permits?
- › What liability, if any, does the district hold?

If minimum size requirements are waived, permanent tiny house units—prefabricated or containers on foundation—could be encouraged by slowly exposing the public and industry to other smaller built forms by expanding the tertiary dwelling policy.

Lessons learned

- › **Consider your work's context.** Tiny homes come in a variety of forms and options, and some may not be suitable for your community or a particular location. Consider the problem you are trying to solve and how tiny homes may or may not be an appropriate solution, where they can be placed, and how they should be used.
- › **Get the data you need to back up your plans.** Gather background information that informs the tiny house proposal on which you're working. Make sure that tiny homes are supported by credible information and not just anecdotes. Leverage the information to support the vision.
- › **Get the community on board.** Hold an open house or similar event to share information and get feedback. Community buy-in is important, especially when the concept of tiny homes is new to the community.
- › **Work with existing codes and legislation.** The BC Building Code and local zoning bylaws exist for a reason, so consider how you can work within their constraints to deliver a supportable and quality final proposal.



View overlooking Squamish and the Squamish River. Image credit: Substatique; Creative Commons

City study no. 4:

District of Squamish, BC

The District of Squamish hopes to create a zoning regulation that will allow moveable and on-foundation tiny houses as a viable form of infill development on existing residential properties in RS1 and RS2 zones, outside the Flood Hazard Area. To make this zoning district feasible, Squamish needs to:

1. Define mobile tiny homes and outline how they differ from other forms.
2. Outline the required zoning amendments to accommodate these dwelling units (outside of the [Flood Hazard Area¹³⁸](#)), similarly to existing accessory dwelling units (ADUs), including setbacks, area and parking requirements.
3. Create a list of viable servicing options similar to an ADU, and foundation types (pad).
4. Create a new intensive Development Permit process and new mobile tiny home Development Permit guidelines to differentiate mobile tiny homes from ADUs and RVs.
5. Create an application process and new building permit review process to allow occupancy of these residential units should new CSA building code standards be created.
6. Update the District of Squamish's existing tiny house webpage with new information, and potentially create a pamphlet once zoning regulation is adopted.

Note: The District uses the term *mobile* over *moveable* and is reflected below.



CONTEXT

Region: Howe Sound

Municipality: District of Squamish

Population: 19,512 (2016, census)

Vacancy rate (rental): 1% (2018, CMHC)

Average cost to buy a single-family home (3 bedrooms):
\$920,000 (June 2019, [zolo.ca](#))

Minimum unit size: None

Average age of the population: 37.5 (2016, census)

Average total income in 2015: \$48,654 (2016, census)

¹³⁸“Flood Hazard Land Use Management”. *Government of B.C.*; www2.gov.bc.ca/gov/content/environment/air-land-water/water/drought-flooding-dikes-dams/integrated-flood-hazard-management/flood-hazard-land-use-management

In approaching this case study, the District of Squamish assumed the following:

- › The community of Squamish will be supportive of mobile tiny homes in residential zones
- › Council will be supportive of mobile tiny home regulations and wants staff to continue with engagement and regulation amendments (that involve these specific amendments and not a new zone for mobile tiny homes)
- › These regulations will provide a more affordable form of infill housing for both the owner and tenant
- › There is a market of mobile tiny homeowners with CSA-approved mobile tiny homes that can make use of these regulatory changes

HOUSING IN SQUAMISH

To date, Squamish allows ADUs on all residential single-family lots to a maximum of 70 m² gross floor area or 90 m², if the property is over 0.2 hectares. Note: these areas are doubled if the unit is situated above a garage. Regulations amended in 2018 now allow for one secondary suite and one ADU on the same property. The parking ratio for the main house is two stalls, and one stall for each additional ADU or secondary suite. Since June 7, 2016, all development cost charges (DCC) were waived for ADUs or secondary suites in order to encourage a diversity of rental options in the market. Since then, 50 ADUs and 33 secondary suite building permits are currently under review or have been issued (July 2019).

The Local Government Act does not allow the district to regulate ADU form, character or massing (includes the sense of space a structure occupies, its interior space and the exterior shape of the structure). Therefore, these dwellings can only be regulated by the district's zoning bylaw and policies that address floor area, height, lot coverage and setbacks. Since most of Squamish is located in a Flood Hazard Area, flood construction levels (FCLs) are very high in most neighbourhoods, meaning that infill ADU development needs to be above a garage. The zoning bylaw does not

differentiate between an ADU in a Flood Hazard Area or in a neighbourhood not affected by flood hazard. This means that while two-storey ADUs are allowed in flood hazard areas that will be experiencing a transition into equally higher single-family homes and duplexes, neighbourhoods that may not need to go higher to meet FCLs may also see these taller ADU structures. In most cases, it makes more economic sense for a homeowner to maximize the ADU size in order to get a better return on the investment. Tensions amongst neighbours have been building as more and more two-storey ADUs are built in predominantly older, bungalow-style, single-family neighbourhoods. An option to allow mobile tiny homes in areas which are not affected by flood hazard, may help alleviate the tension larger ADUs are causing. It may allow for more design reviews to help these structures fit better into the existing neighbourhood.

The housing market in Squamish has changed since 2016. Currently, the district is reviewing its DCC exemption incentive, which may no longer be available in the future. The cost of building an ADU requires homeowners to fund the upfront costs of development; financially this is not a feasible option for all. Mobile tiny homes can offer homeowners an opportunity to receive a second rental income without onerous upfront costs. They would only need to build a secure pad and install proper municipal servicing connections.



Kequyen's tiny house in Squamish. Image credit: Kequyen Lam, Tiny House Swoon

Ideally, mobile tiny homes would not replace ADU development potential, but would offer more infill development options to a broader range of homeowners and single-family lots. This could potentially make homeownership more affordable. It would also provide a home to a growing market of mobile tiny homeowners who want to own their unit, but are willing to rent the land it resides on in order to be closer to or within the city. Tiny homeowners would need to pay monthly rents on top of the initial investment of purchasing or building a certified mobile tiny home.

Whether certified mobile tiny homes are considered affordable housing is still up for debate. This option requires both the homeowner and renter to make initial investments, and although it may not be traditional “affordable housing,” the District of Squamish believes that supporting diversity of housing can be one option to help tackle the affordability crisis many cities are facing.

TINY IMPACT IN SQUAMISH

The District of Squamish is continuing its exploration of mobile tiny homes, but acknowledges the building code and lack of CSA standards that do not yet recognize these homes as allowable dwelling units. Squamish’s council has the authority to approve mobile tiny homes as a legal use in its zoning and servicing bylaws, should it want to. Mobile tiny homes, however, will remain illegal unless provincial building codes are amended to recognize them as allowable dwelling units.

Squamish’s geography also adds to the complexity. Most of the district’s residential areas are within the floodplain and for many safety reasons, provincial regulations do not support placing tiny homes in these areas. This significantly limits where they could be allowed. There is hope that should the BC Building Code acknowledge mobile tiny homes as dwelling units, that Squamish could support this form to address the growing interest in mobile tiny homeownership, and make housing more affordable in the Sea to Sky region.

“Mobile tiny home regulation or guidelines—in terms of location, setbacks and materials used—would likely not be overly complicated or time-onerous to create or review (assuming a development permit would be required). The biggest challenge is whether we can give a tiny house on wheels a final occupancy permit. Servicing, planning, engineering, fees...this can all be worked out by a municipality. The gap is the building code, and that decision is beyond a municipality’s control and requires industry input.”

—Kerry Hamilton, Planner, District of Squamish

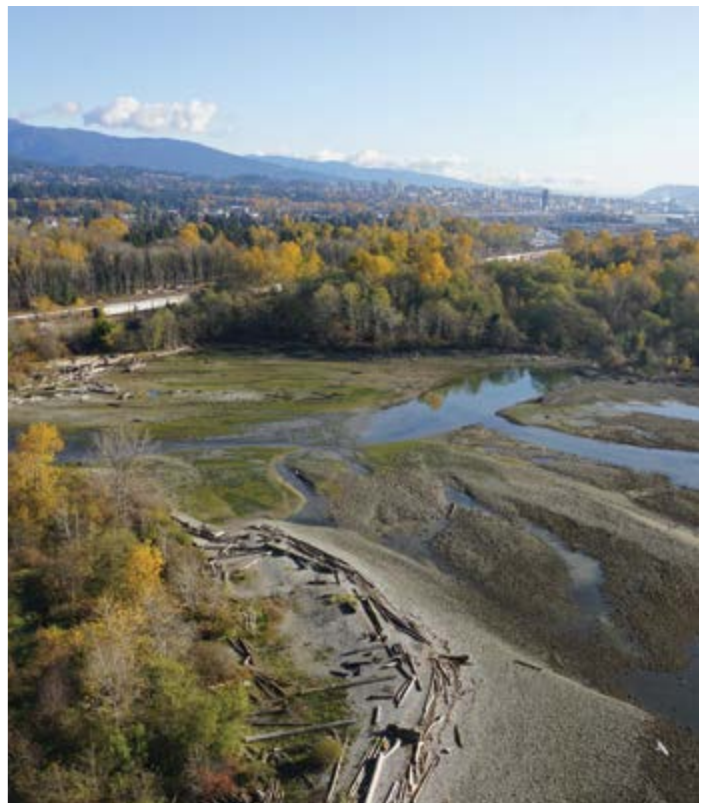

Floodplains in Squamish. Image credit: Bob Mackin, theBreaker

SQUAMISH AND TINY HOUSE WORKSHOP FINDINGS

On June 13, 2018, the District of Squamish, in collaboration with the BC Tiny House Collective and Light House, hosted a multi-stakeholder internal workshop to map out the project scope, process and framework. They looked at what needs to be done and how, in order to create new regulations, policies and processes to permit mobile tiny homes on existing RS1 and RS2 zones as a viable form of accessory dwelling unit. In attendance were staff from the building, planning, engineering, operations and fire departments, as well as members of this report's research team, tiny home builders and an owner. Three main areas were investigated: planning, engineering and operations, and building and fire. Here are the findings of this session:

(See Appendix G for post-workshop comments and questions.)

1. Planning: Moveable tiny house definition, outline and zoning parameters

A. TEAM IDEAS

- › Need to distinguish moveable tiny homes from RVs; tiny homes are non-motorized and require a vehicle to be moved (either using a tow truck or a hitch)
- › Units need to look like permanent homes, and may require skirting or cribbing of wheels; the hurdle being that guidelines for form and character need to be created; need to create a Development Permit (DP) for mobile tiny homes: should make this a concurrent application for both DP and building permit (BP)
- › Would likely follow the same regulations as accessory dwelling units (laneway homes) and include: setbacks, the number of ADUs allowed per lot, placement of ADU on lot (not in front of property); may need to consider setback from principal building

- › Need to create size maximums, size should correspond with transportation width, length and height regulations
- › Would require a permanent pad, and approved location on the property; would need to be placed on a fixed location; would need to be a serviced pad with gravel or paved surface (to be determined)
- › Require one parking stall per unit
- › The unit would remain on wheels, therefore, would need to be secured, this would be reviewed at the building permit stage
- › The mobile tiny house would need to meet a CSA standard, ideally a new CSA standard should be created; the problem with using the existing RV and park model CSA standards is that it would conflict with current zoning that allows for modular homes; the tiny house definition should include a CSA standard

B. GROUP QUESTIONS AND COMMENTS

- › If we are after affordable housing, why not RVs? Why are we excluding CSA-Z241 RV as an option? Is it about safety or the form?
- › How will we mitigate short-term rentals?
- › Who will enforce this? Planning?
- › The pad is a small investment and tiny homes can be a mortgage helper

2. Engineering and operations: Viable servicing and foundation options

A. TEAM IDEAS

- › Modify existing laneway house program to allow already-permitted secondary and accessory dwelling units on single-family lots
- › Much of the program would be in the hands of the building department

- › Units need to be fully hooked up to municipal services: water, sewage and electrical (BC Hydro)
- › Advocate to expand to all zones, beyond RS1 and RS2, where flood levels are met; could elevate the pad (not the tiny house) to accommodate; would require a geotech, but not if you meet the bylaw
- › Could use servicing from the main house; doesn't require a separate water and sewer hookup

B. GROUP QUESTIONS AND COMMENTS

- › Lots don't require laneway access to be eligible to host a moveable tiny house; could use a crane to place the tiny house on the lot
- › Land/homeowners would apply for the building permit and supply servicing; owner would pay the cost of the pad and servicing; mobile tiny homeowners would require a DP application and would be at the owners' expense; when a mobile tiny home vacates, each following home will require a new DP to discourage transient use
- › Does the pad need maintenance? The anchors? Who would enforce these regulations? Would this need to be checked with each new DP and hook up?
- › Could the property owner do a pad without a tiny house owner in mind? Yes
- › What about propane? Gas? What would a standardized hookup look like? What would be the additional cost to add propane/gas?
- › What about off-grid grey and black water management systems? How can we regulate the use of composting toilets?

3. Building and fire: building permit review process to allow occupancy to CSA-approved tiny homes

A. TEAM IDEAS

- › Not a big difference from a laneway house
- › What about fire spread? Follow current guidelines
- › CSA Z240-MH meet snow load requirements; the CSA park model could be upgraded to meet snow load requirements
- › New CSA regulation required, RV standard does not allow for "lofts" or ladders that are typically seen in tiny home design. Could potentially approve under existing CSA standards if those components are not in the design, might promote larger tiny homes; there may be other concerns with using RV standards in a mobile tiny home

B. GROUP QUESTIONS AND COMMENTS

- › Squamish does not allow lots to be subdivided
- › Would need to set a size requirements or at least a maximum unit size, to avoid mobile homes in backyards
- › Will regulate through lot coverage
- › If a pad is empty, the homeowner could shut off the valve on servicing to avoid unnecessary expenses
- › Would an empty pad encourage RVs?
- › Could we allow multiple tiny homes on wheels on one lot?; at this stage, Squamish is only looking at infill



go, go TINY. Image credit: BC Tiny House Collective

10 | Conclusions and recommendations

There are many barriers to tiny living. To date, political, financial and cultural norms have dictated how tiny homes have been received in communities across B.C.; with mixed success. However, the biggest challenges lie in the relationship between demand and regulations.

Currently we have tiny homes on wheels, with builders, designers, pilot projects and intentional communities focused on all things tiny, yet lacking standardization and regulation. We have urban and rural areas without places for tiny homes to set-up freely. This uncertainty and inconsistency around regulations limits the number of people who are willing to invest in this type of housing. With inconsistency and lack of investment, there is still so much uncertainty about mobile tiny homes, as with prefab and container units in some communities.

Moveable tiny houses can be a viable housing form—one that is affordable and accessible—but not without the collaboration of multi-players. Without a joint effort, the typology is forever stereotyped by the motorized RV culture. It cannot fully take ownership of its potential and expand into the more accepted category enjoyed by prefab and container homes. In fact, until the form is viewed as an allowable permanent dwelling, in essence a home, insurance and financing remain a significant barrier. Until this changes, tiny houses will continue to be available only to those with deep pockets, and with access to land outside municipal and zoning boundaries.

The way around this is to address the most pressing challenge to tiny houses; safety. The findings of this report are not suggesting that codes or standards be removed, or that cumbersome zoning bylaws or legalization processes be developed. They recommend closing the gap between how we see and use tiny homes in today's society. They demonstrate the need to define and recognize the potential to use tiny homes as emergency response shelters, workplaces, primary dwelling units, rentals and other uses.

Tiny homes are not suitable for everyone in a city context. As the user satisfaction survey shows, individuals who choose to live tiny are most affected by a lack of security as it pertains to tenure.

New industry standards can certainly change this. By addressing these barriers, we can systematically allow this form to be more accessible within urban and rural landscapes. A more affordable tiny house has the potential to greatly expand:

- › municipal laneway programs
- › infill densification strategies in urban contexts
- › affordable housing options
- › housing options for individuals experiencing homelessness
- › opportunities for aging-in-place housing
- › intergenerational living
- › income-generation for property owners

To move forward, the following recommendations are suggested.

› **INDUSTRY**

As per findings from research and the Tiny House Builders' Survey, revisiting industry standards such as CSA, and creating a new category specific to moveable tiny homes is recommended. The category should separate tiny homes from motorized vehicles, towable RVs and temporary small travel trailers. While the DIY culture may take some time to adjust, providing regulated owner-builder requirements within the tiny house building

industry will ensure that future tiny builds are safe from a fire, seismic and structural perspective, and be more consistently accepted in communities across B.C. Lenders and insurers, will be more likely to support this form, leading to easier access for buyers. Any barriers to prefab or container units should be considered and addressed at the same time.

› **FEDERAL AND PROVINCIAL GOVERNMENTS**

The National Building Code will need to recognize and define tiny homes as an allowable dwelling unit and provide specific building requirements. This will set the tone for provincial standards and encourage revisions to be included into Part 9 of the BC Building Code.

A review of the Residential Tenancy Act will be required to assess how owning a home, but not the land, impacts landlord and tenant rights and municipal liability. There is precedence in the United States via Appendix Q amendments within the International Residential Code, which can be used as an example. Governments and tiny home advocates can leverage existing research, results and partnerships.

› **LOCAL GOVERNMENTS**

Our case studies demonstrate the importance of research, collaboration, outreach and sharing of best practices. Introducing moveable, prefabricated and container tiny homes into the larger conversation around the missing middle is recommended. They should be considered unconventional (but more affordable) accessory dwelling units. Further, municipal leaders should be encouraged to find solutions that meet their affordable housing targets without sacrificing quality and control. This can be achieved by identifying feasible tools other than Temporary Use Permit or lengthy rezoning processes. Municipalities should engage industry and their citizens in forums, workshops, tours and open houses that explore densification, alternative forms and less traditional types of foundations. This may help to educate the broader community on the form, its uses, users and benefits.

Other important actions include:

- › Removing minimum size requirements for permanent dwellings
- › Amending zoning and bylaws to permit laneway homes (and secondary suites) on the same single-family residential lot
- › Creating a specific definition of a tiny house
- › Permitting prefabricated, container and moveable tiny homes as part of a pilot project, in specific zones or across areas zoned for residential purposes

In doing so, these actions may also inspire decision-makers to plant seeds for a vibrant green economy and industrial growth around tiny houses, including green building construction, deconstruction, material reuse, waste management systems and off-grid technologies. This may lead to a thriving but regulated tiny house industry and market. Equally, it may create more career and financial opportunities for designers, builders, financiers, buyers, and landlords among others. These steps will ultimately support B.C. citizens in their quest for their own version of affordable housing.

This proposed approach—one that is rich in strategy, engagement and education—requires multi-stakeholder commitment and contribution. Through this collaboration, we can open the doors to an enforced and safe tiny house market, and begin to explore how tiny can fit in our neighbourhoods.

11 | References

See footnotes for all other references cited in this report.

“Go Tiny: A Project on Tiny Houses.” *BC Tiny House Collective*;

bctinyhousecollective.com/wp-content/uploads/2016/10/Go-Tiny_A-project-on-tiny-houses_Final.pdf

Cresnar, Gregor. “Friends”; thenounproject.com/search/?q=friends&i=798458

Fecteau, Pete. “Arts And Culture”; thenounproject.com/search/?q=culture&i=13644

Fecteau, Pete. “Public Health”; thenounproject.com/term/public-health/3475/

Gattino, Silvia, Piccoli, Norma De, Fassio, Omar, & Rollero, Chiara. “Quality of Life and Sense of Community. A Study on Health and Place of Residence”. *Journal Of Community Psychology*, 41(7), 811-826 (2013). doi:10.1002/jcop.21575

Jackson, Laura, E. “The Relationship of Urban Design to Human and Health Condition”. *Landscape and Urban Planning*, 64 (2003); [doi.org/10.1016/S0169-2046\(02\)00230-X](http://doi.org/10.1016/S0169-2046(02)00230-X)

Kahn, Lloyd. “Cozy, Affordable and Inspiring: Tiny Homes”. *Mother Earth News*, (253), 40-45 (2012);

thefreelibrary.com/Cozy%2C+affordable+and+inspiring+Tiny+Homes%3A+start+small%2C+and+you+can...-a0300443246

Laliberte, Shari. “Young People, Socioeconomic Processes, and Youth Mental Health Promotion.”

PhD diss., *University of British Columbia*, 2015; circle.ubc.ca/

Lin, Hea Poh. “Monk”; thenounproject.com/search/?q=meditation&i=583034

MacMillan, T. “The New American Life.” *Rodale’s Organic Life*, 1(2), 86-99 (2015)

Mather, Cam. “Lessons From Off-grid Living”. *Mother Earth News*, (266), 26-29 (2014)

Maynard, Kathleen. “Where Do Tiny Houses Fit?” *Building Science*; homebuildercanada.com/2902_bldg-sc.htm

Mikkonen, Juha, & Raphael, Dennis. “Social Determinants of Health: The Canadian Facts.”

York University School of Health Policy and Management, (2010); thecanadianfacts.org/

Murphy, Mary. “Tiny Houses as Appropriate Technology.” *Communities*, (165), 54-59 (2014)

Nolan, Val Jr. & Horack, Frank E. Jr. “How Small a House? Zoning Minimum Space Requirements.”

Maurer School of Law Indiana University, Paper 1077, (1954)

Quillen, K. “Inspired, Affordable Tiny Homes that Travel.” *Mother Earth News*, (276), 34-38, (2016)

Spidell, Chuck. “Trees”; thenounproject.com/term/trees/50447/

Vannini, Phillip, & Taggart, Jonathan. “Do-it-yourself or Do-it-with? The Regenerative Life Skills of Off-grid Home Builders.”

Cultural Geographies, 21(2), 267-285 (2014). doi:10.1177/1474474013493577

Vassenden, Anders. "Homeownership and Symbolic Boundaries: Exclusion of Disadvantaged Non-homeowners in the Homeowner Nation of Norway." *Housing Studies*, 29(6), 760-780 (2014). doi:10.1080/02673037.2014.898249

Vera, Isabela. "Tiny Houses: Live Big by Going Small." *Alive: Canada's Natural Health & Wellness Magazine*, (399), 84-86 (January 18, 2017); alive.com/lifestyle/tiny-houses/

Wilson, Alex. & Boehland, Jessica. "Small is beautiful: Resource use, and the environment." *Journal of Industrial Ecology*, 9.1-2, (2005). Doi: 10.1162/1088198054084680

Wyatt, A. "Tiny Houses: Niche or Noteworthy?" *Planning*, 82(2), 39-42, (2016)

Yulianto, Arif Fajar. "Home"; thenounproject.com/search/?q=house&i=844560

Research conducted by Vancouver Community College

Appendices



View of Quixote Village from across the pond. Image credit: Quixote Communities

Appendix A: Tiny Home User Satisfaction Survey

Appendix B: Proposed Code Change Requests to the National Building Code

Appendix C: Tiny House Builder's Survey

Appendix D: City of Grand Forks—A Guide in Tiny Houses in Grand Forks

Appendix E: City of Grand Forks—Development and Temporary Use Permit

Appendix F: Quixote Village—Fundamentals and Budget Breakdown

Appendix G: District of Squamish—Post-workshop Comments and Questions

Appendix A:

Tiny home user satisfaction survey

See page 27 for more information on this survey.

TINY HOMEOWNERS

72% of the residents are women

70% are 40 years-old or older

77% of residents lived with a pet in their tiny house (primarily cats and dogs)

81% live in their tiny house alone

19% live in their tiny house with one other person

16/19 of the respondents considered their tiny house as their permanent dwelling in which they live 80% or more of the year

No one that completed the survey owned the land on which their tiny house resides; the tiny home residents either rent the land, have permission to use it for free (some in exchange for labour) and others are parked illegally. Renters are paying on average \$400 per month.

Household incomes varied from **under \$15,000** to upwards of **\$100,000 to \$150,000**

Q. What is your gender?

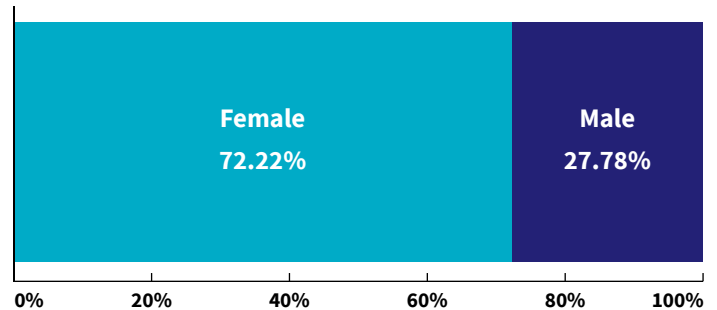

Q. Do you have a pet living with you in your tiny house?

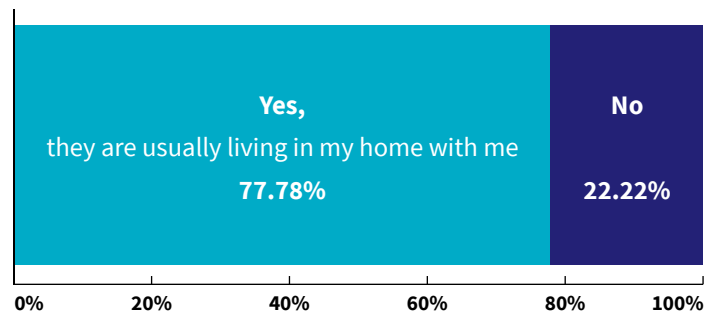

Q. What kind of pets live with you? (Select all that apply)

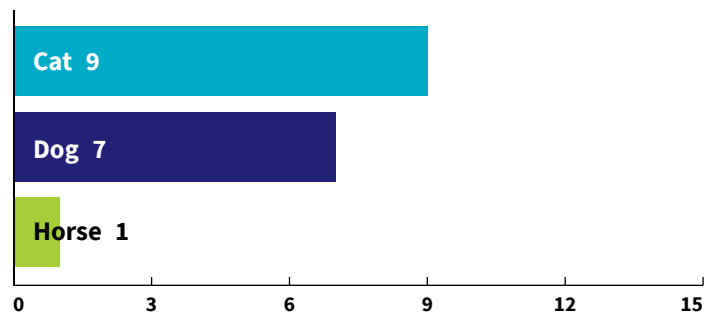

TINY HOUSE FINANCING

78% of tiny home residents own their tiny house and bought it for under \$100,000

0% of the homeowners financed their homes with a mortgage

43% through personal savings

28% through a personal loan or line of credit

14% via a private lender

1 of the respondents was able to access funds from his/her RRSP via the Canadian government **Home Buyers' Plan**¹³⁹ program towards the downpayment of a tiny house

Q. Do you currently own or rent your tiny home?

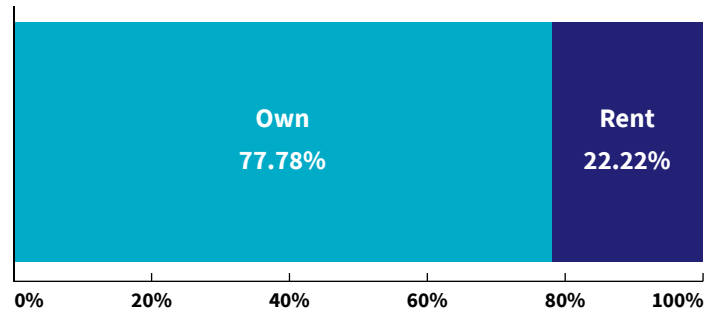

Q. How much did you buy your tiny house for?

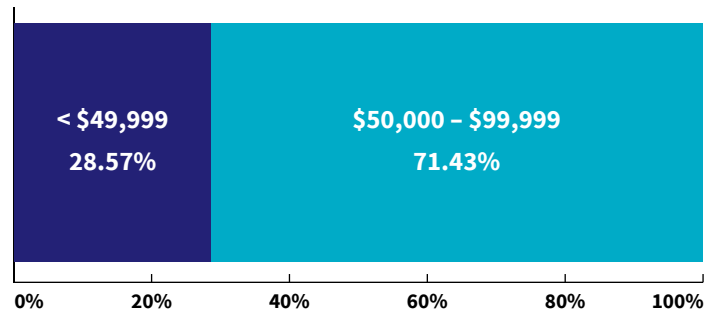

Q. Please indicate how much you agree/disagree with the following statements regarding your tiny house.

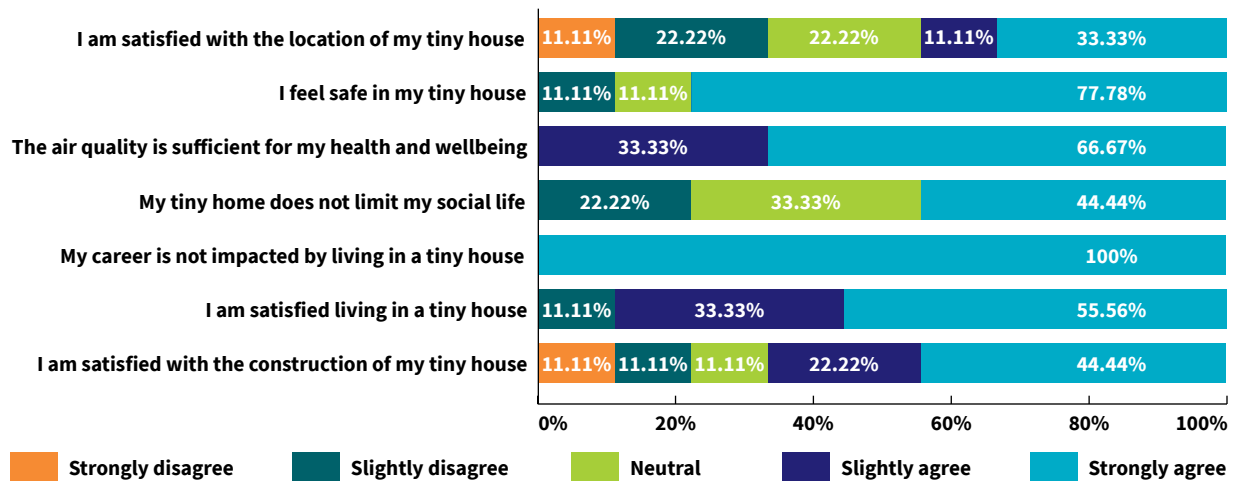

¹³⁹“Home Buyers’ Plan”. Government of Canada; canada.ca/en/revenue-agency/services/tax/individuals/topics/rrsp-related-plans/what-home-buyers-plan.html

Appendix B:

Proposed code change requests to the National Building Code

Follow the links to read the code change requests to the National Building Code as proposed by the Canadian Home Builders' Association in March 2017.

Also see within this report Section 6: Tiny Homes, Codes, and Standards.

CCR DIVISION A, 1.1.1.1.(2) APPLICATION OF CODE

bctinyhousecollective.com/wp-content/uploads/2019/09/CCR_-Div.A-1.1.1.1.2_Application-of-Code.pdf

CCR DIVISION A, 1.4.1.2. DEFINED TERMS—FACTORY-CONSTRUCTED BUILDING

bctinyhousecollective.com/wp-content/uploads/2019/09/CCR_-Div.A-1.4.1.2._Tiny-Houses_Defs-Factory-Built.pdf

CCR DIVISION A, 1.4.1.2. DEFINED TERMS—MEZZANINE

bctinyhousecollective.com/wp-content/uploads/2019/09/CCR_-Div.A-1.4.1.2._Tiny-Houses_Defs-Mezzanine.doc.pdf

CCR 9.5.1.2.(1) COMBINATION ROOMS

bctinyhousecollective.com/wp-content/uploads/2019/09/CCR_9.5.1.2.1_Tiny-Houses_Combination-Rooms.doc.pdf

CCR 9.5.3.1.(1),(2) CEILING HEIGHTS

bctinyhousecollective.com/wp-content/uploads/2019/09/CCR_9.5.3.1.12_Tiny-Houses_Ceiling-Heights.doc.pdf

CCR 9.5.5.1.(1) DOORWAY OPENING SIZES

bctinyhousecollective.com/wp-content/uploads/2019/09/CCR_9.5.5.1.1_Tiny-Houses_Doorway-Size.doc.pdf

CCR 9.5.5.3.(1) DOORWAYS TO ROOMS WITH A BATHTUB, SHOWER OR WATER CLOSET

bctinyhousecollective.com/wp-content/uploads/2019/09/CCR_9.5.5.3.1_Tiny-Houses_Doorways-Serving-Bathrooms.doc.pdf

CCR 9.8.1.1. APPLICATION OF SECTION 9.8. STAIRS, RAMPS, HANDRAILS AND GUARDS

bctinyhousecollective.com/wp-content/uploads/2019/09/CCR_9.8.1.1._Tiny-Houses_Stairs.doc.pdf

CCR 9.8.8.1. REQUIRED GUARDS

bctinyhousecollective.com/wp-content/uploads/2019/09/CCR_9.8.8.1._Tiny-Houses_Guards.doc.pdf

CCR 9.9.10.1. EGRESS WINDOWS OR DOORS FOR BEDROOMS

bctinyhousecollective.com/wp-content/uploads/2019/09/CCR_9.9.10.1._Tiny-Houses_Escape-Windows.doc.pdf

CCR 9.10.19.3. SMOKE ALARMS

bctinyhousecollective.com/wp-content/uploads/2019/09/CCR_9.10.19.3._Tiny-Houses_Smoke-Alarms.doc.pdf

CCR 9.23.13.2.(2) TABLE A-9.23.13. APPLICATION OF LATERAL LOAD REQUIREMENTS

bctinyhousecollective.com/wp-content/uploads/2019/09/CCR_9.23.13.2.2_Tiny-Houses_Lateral-Loads_A-Note-Table.pdf

CCR 9.23.13.2.(2) REQUIREMENTS FOR HIGH WIND AND SEISMIC FORCES

bctinyhousecollective.com/wp-content/uploads/2019/09/CCR_9.23.13.2.2_Tiny-Houses_Lateral-Loads.doc.pdf

CCR 9.31.4.1. REQUIRED FACILITIES (PLUMBING)

bctinyhousecollective.com/wp-content/uploads/2019/09/CCR_9.31.4.1._Tiny-Houses_Plumbing-Fixtures.doc.pdf

Appendix C: Tiny house builder's survey

Below are findings from the survey drafted for this research and completed by BC tiny house builders in 2018. Also see page 67 of this report for more on this survey's findings.

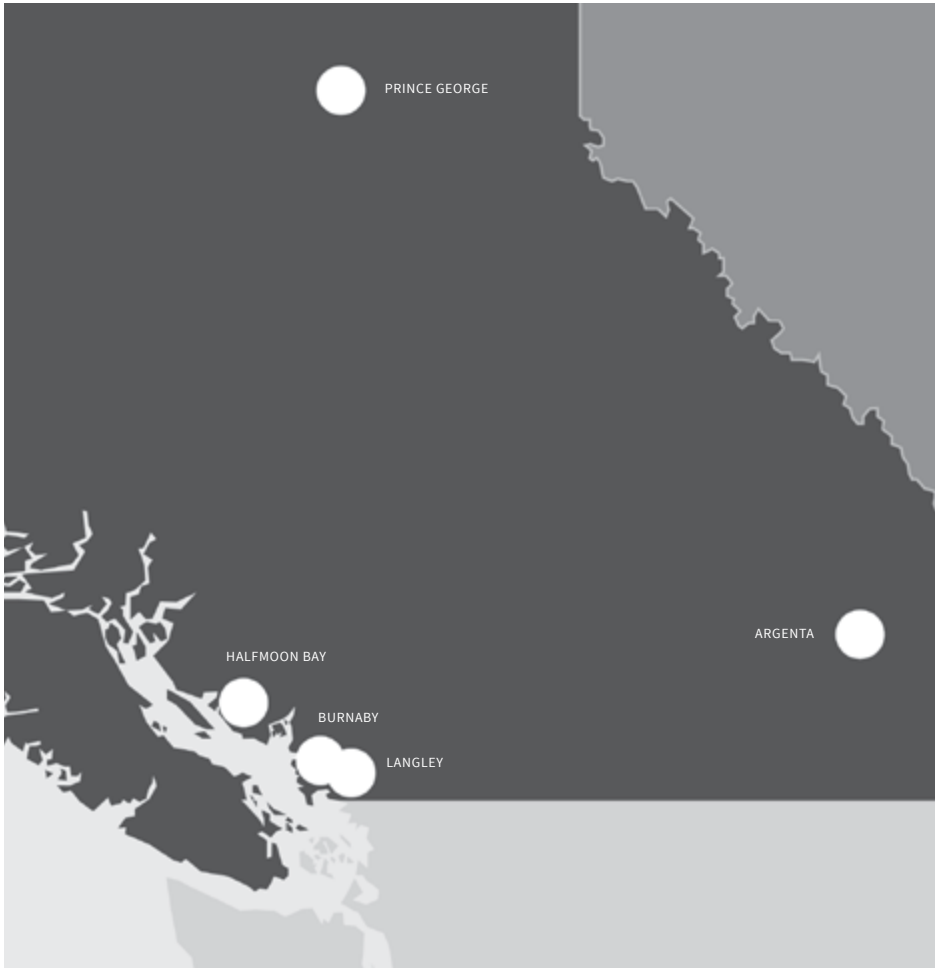

“At this time, there is no CSA certification, however, all units are provided with quality assurance for up to one year.”

—Respondent, tiny house builder survey, 2018

TINY HOME BUILDER'S SURVEY RESULTS

How long have you been building tiny houses?

- Two or less years (20%)
- Three to six years (60%)
- Seven to ten years (20%)

To your knowledge, how are the tiny houses you're building being used?

- House for full-time living (100%)
- Some served double-duty, including:
 - Vacation home/rental (60%)
 - Workshop or office (40%)

Do you offer new buyers any financing options?

- No (80%)
- Financing no longer provided (20%)

Do you offer limited warranty on moveable and prefab tiny homes?

- Yes (40%)
- No (20%)
- Depends (20%)
- Other (20%)

When does the warranty initiate?

Upon full payment of the tiny house (40%)

Upon delivery of the tiny house (40%)

N/A (20%)

How long is the homeowner covered under the warranty?

One year (40%)

Two years (20%)

Depends (20%)

What is covered under the warranty?

Building shell, roof, windows, siding

Is the warranty included in the cost of purchase?

Yes (40%)

No (20%)

Depends (40%)

Is the warranty transferable if the unit is rented or sold?

Yes (25%)

No (75%)

What skills or trade certification do you and your employees, if any, have/hold?

Red seal carpenter, sawyer, joiner, plumbing, bar welding, and none

Do you use salvaged/reclaimed building or other materials in the construction of your units?

Yes but mostly new (75%); no (25%).

What types of tiny houses do you build?

Respondents build various forms; answers included: tiny homes on wheels, sheds, and prefab, yurts and small cabins

How many models or prototypes do you offer, if any?

Custom, 2–7

What upgrades do you offer?

Better windows, grades of wood, timber frame roof system, infloor heating, storage, stains, solar, custom kitchen/woodworking titling; anything you like

What are the demographics of your tiny house buyers?

Couples aged 30–50, and single women aged 20–30 and 50+ (60%); couples aged 30–50, 50+ and families of 3 or more (40%)

“It would be great if municipalities could accommodate tiny homes, there is clearly a desire and a movement with people who want to downsize and live sustainably.

Right now they’re made to feel as outlaws because the regulations are not in place and things are often not done legally. Zoning and regulations for tiny homes should really be in place within the near future.”

—Anonymous, *Tiny House Builders’ survey respondent, 2018*

What is the average cost of one of your tiny houses?

\$250 to \$300 per square foot; depends, \$40,000 to \$80,000

Do your clients want their tiny house built to a specific certification/standard?

Yes (60%); no idea (40%)

Are your units certified?

Various answers included: engineered for structural, silver seal for electrical, plumbing and gas inspected, ICBC, personal accountability

What is the cost to you to certify per unit?

“Structural cost is \$3000, which gets you a foundation plan, drawing off building stairs and entrance designs. Electrical is \$250, plumbing is about \$250.”

Appendix D:

City of Grand Forks -

A guide to tiny houses in Grand Forks

See: bctinyhousecollective.com/wp-content/uploads/2019/09/Grand-Forks_A-Guide-to-Tiny-Houses-in-Grand-Forks.docx

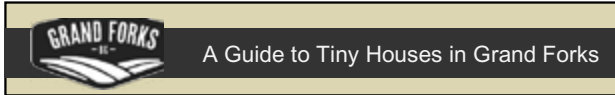

Tiny Houses on Wheels are allowed in Grand Forks!

In early 2018, following public consultation and a public hearing, Grand Forks City Council adopted an amendment to the Official Community Plan and Zoning Bylaw to accommodate *tiny houses on wheels* in the City. Before placing a tiny house on property in the City, development and building permits must be obtained to ensure that the tiny house fits in with the neighbourhood and is safe and livable.

What is a Tiny House on Wheels?

A *tiny house on wheels* is a dwelling unit on a wheeled chassis, greater than 12 square metres (129 square feet) and less than 29 square metres (312 square feet). A tiny house in Grand Forks must be constructed to be used as a full-time residence in this climate and must comply with the current British Columbia Building Code. If premanufactured, the tiny house must comply with the CSA Z240 or Z240RV standard.

Tiny houses can be either a second smaller home on a lot (accessory dwelling unit), or in some cases, be the only home on a lot. Both options require the land owner to apply for and obtain permits from City Council.

Why are Tiny Houses good for Grand Forks?

Tiny houses provide an alternative housing solution for a variety of people, including those who would like to downsize, relatives of homeowners, aging parents and renters. Rental income can help to reduce housing costs for homeowners (i.e., mortgage helpers), and increase options for affordable rental housing in the City. Tiny houses use very little city infrastructure, providing a sustainable and economical way to increase and diversify the housing stock in the city.

Where are Tiny Houses on Wheels permitted?

Tiny houses on wheels are permitted outright in industrial zones in Grand Forks. In all other zones (i.e., residential) they must receive approval through a permit process (combined Development and Temporary Use Permit). This process involves an application and review process, public notification and consideration by City Council.

Before buying or building a tiny house, please contact City staff at 250-442-8246 or info@grandforks.ca to learn about the process and requirements for placing a tiny house on your property.

I want to place a Tiny House on Wheels on my lot. What do I need to do?

1. Review the regulations and guidelines for tiny houses on wheels in the Zoning Bylaw and the Official Community Plan.
2. If you are planning to place a tiny house on a residential property, you must apply for a combined development/temporary use permit. Before you proceed, contact city staff to discuss the application requirements (250-442-8266 or info@grandforks.ca).
3. Prepare your plans and apply for a [Combined Development/Temporary Land Use Permit](#) which includes a questionnaire to ensure your application meets the guidelines for tiny houses in Grand Forks. When you are ready, contact City staff to book an appointment to submit your application.
4. Your application will be forwarded to City Council for authorization to proceed to public notification, which includes advertising in the local paper and notifying neighbouring property owners.
5. Your application will proceed to Council for a second time where, based on any comments received by the public, Council will approve (or deny) the permit.
6. The permit will be issued and be valid for a period of three years. A renewal for an additional three years can be applied for prior to the expiry date of the original permit.
7. You may apply for a building permit.
8. When all permits are in hand, you are ready to build or place the tiny house on your land.

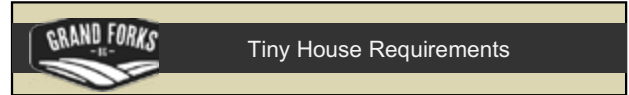

Once you have confirmed that a tiny house on wheels is suitable for your property, it must be sited and designed in accordance with the following regulations and guidelines.

Zoning Regulations

In addition to the zoning requirements regarding setbacks, height and lot coverage in the applicable zone, *tiny houses on wheels* must comply with the following regulations (as per Section 23 of the Zoning Bylaw):

1. A tiny house on wheels must be constructed to be used as a full-time residence according to the current British Columbia Building Code or the CSA Z240 or Z240RV standard if it is premanufactured.
2. For residential zones permitting a single-family dwelling with a floor area between 18 and 29 square metres or a garden suite, the tiny house on wheels must be converted to a single-family dwelling or a garden suite by placement on a full-depth perimeter or point support foundation, subject to the conditions of a building permit from the City.
3. A person must obtain a temporary use permit to place a *tiny house on wheels* that is not converted to a principal dwelling or garden suite in a zone where it is not permitted, such that:
 - (a) bonding sufficient for removal of the tiny house on wheels is provided to the City before the time of placement; and
 - (b) the tiny house on wheels is removed at the end of the permit period; or
 - (a) to remain on the property the tiny house on wheels must be converted as per no. 2 above.

Development Permit Area Guidelines

Tiny houses on wheels must comply with Section 14.10 of the Official Community Plan: *Accessory Dwelling Unit and Tiny House Development Permit Area (ADU DPA)*, as outlined below:

Buildings and Structures

1. Orient buildings to maximize opportunities for passive solar heating and natural lighting.
2. Consider adaptable design and universal accessibility.
3. Use natural ventilation and cooling systems.
4. Consider the use of green roof systems to reduce stormwater runoff, reduce energy costs and improve visual appearance.
5. Use building products that demonstrate re-use, upcycling and green technology.
6. Developments are encouraged to seek Passive House, LEED, or other sustainability certification.
7. Where garages or carports are necessary, design them to be recessed within the building or set back from the front face of the building.
8. Buildings should be clad with durable, aesthetically acceptable and environmentally friendly materials at least as good of quality as primary dwelling; vinyl and aluminum siding is not acceptable.
9. Tiny houses on wheels must be skirted with a finished insulating material the same quality as or complementary to the cladding of the tiny house.
10. In all residential zones, tiny houses on wheels must have a deck or porch attached, with appropriate stairs or ramp, to signify that they are semi-permanent in nature.

Utilities / Servicing

11. Buildings must share the services of the primary unit as per the City bylaws for water, sewer and electrical services.

Parking / Access

12. Entrances should face the street (or laneway, if sited on a lane) and have direct pedestrian access from the street. Windows should provide "eyes on the lane" for security.
13. Shared driveways are encouraged to reduce paved surfaces.
14. Provide vehicle access via rear lanes where they are available.

Screening and Landscaping

15. Provide private outdoor space of at least 9 square metres for each of the primary residence and accessory dwelling unit.
16. Provide for clothesline use.
17. Limit the use of potable water for landscape irrigation.
18. Provide natural filtration of rainwater into the site through techniques including raingardens, rainwater collection systems, bio swales and permeable paving or crushed rock for driveways.

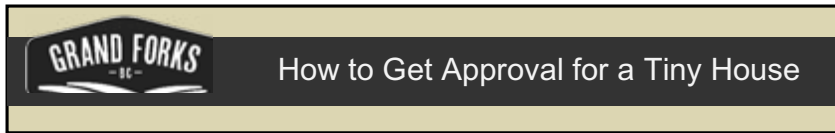

1. Pre-application meeting

Contact City staff to discuss your ideas and preliminary plans for your tiny house. Note that you will be required to apply for a Combined Development/Temporary Use Permit and a Building Permit. City staff will help to define the next steps in the process. Although the City will notify neighbouring property owners about your application for a tiny house, it is suggested that you discuss your proposal with your neighbours to gain their support.

2. Apply for a Combined Development/Temporary Land Use Permit

This permit is required to ensure that the form and character of the tiny house fits into the existing neighbourhood and that it meets the regulations and guidelines. Make an appointment with City staff to submit your application. A [Combined Development/Temporary Land Use Permit Application](#) must be accompanied by a completed questionnaire and drawings/plans, including:

A legible site plan, drawn to scale, showing the following:

- a. The boundaries and dimensions of the subject property.
- b. The location, setbacks and dimensions of the proposed and present buildings.
- c. The location of off-street parking.
- d. The location of proposed access roads, pedestrian access routes, screening, landscaping and fencing.
- e. Photos and/or elevation plans showing height, exterior finishing and colour, windows and doors and roof pitch.

The questionnaire will help determine if your proposed tiny house meets the Development Guidelines in the Grand Forks Official Community Plan (OCP).

3. Plan check and referral

The application will be checked by City staff to ensure that it is complete and that the proposed tiny house conforms to City requirements. Staff may also refer the application to relevant departments and external agencies, including the Fire and Public Works Departments, Interior Health and the Ministry of Transportation & Infrastructure (if it is within 800 metres of a provincial highway).

4. Application is considered by Grand Forks City Council for the first time

An initial staff report with recommendations will be considered by City Council at one of its regular Council meetings. You are welcome to attend to answer any questions. Council will pass a resolution authorizing (or not) staff to proceed with the public notification process.

5. Neighbours are notified of the proposal for a tiny house on wheels

All landowners within 30 metres of your property will be notified in writing of your application and invited to ask questions and/or provide comments to City staff. All written comments will be transmitted to City Council when it considers your permit application for final approval.

6. Proposal is advertised in the local newspaper

The proposal for a tiny house is advertised in the local newspaper to advise the public of the application and when it will be given final consideration by City Council.

7. Application is considered by Grand Forks City Council for the second time

After hearing any comments received as a result of the above public notification process, City Council will pass a resolution to approve (or deny) the permit.

8. Combined Development/Temporary Land Use Permit is issued

City staff will then issue the permit (with or without conditions). This permit will be sent to the Land Titles Office and registered on the title of your property (as both a development permit and a temporary land use permit).

9. Apply for a Building Permit

Once your Development Permit is issued, you may apply for a [Building Permit](#). It is noted that in some cases a building permit and development permit application may be reviewed by City staff concurrently. Information respecting building permits and inspections can be found [here](#).

Appendix E: City of Grand Forks— Development and Temporary Use Permit

See: bctinyhousecollective.com/wp-content/uploads/2019/09/Grand-Forks_Tiny-House-on-Wheels-Combined-DevelopmentTUP.docx

THE CORPORATION OF THE CITY OF GRAND FORKS
7217 - 4TH STREET, BOX 220 - GRAND FORKS, BC V0H 1H0 · FAX 250-442-8000 · TELEPHONE 250-442-8266



**APPLICATION FOR A TINY HOUSE ON WHEELS
COMBINED DEVELOPMENT/TEMPORARY USE PERMIT**

APPLICATION FEE **\$200.00 (DP)** File No. 09-4550-20- Receipt No. _____
 \$750.00 (TUP)

These permits are a requirement of the City of Grand Forks Official Community Plan Bylaw No.1919 (Section 14.10) and Zoning Bylaw No. 2039 (Section 23) for the placement of a Tiny House on Wheels on residential-zoned properties in the City of Grand Forks.

Applicant Information

Registered Owner(s): _____

Please note: If the applicant is other than the registered owner(s), an Agent's Authorization form is required.

Owner's Mailing Address: _____

E-mail Address: _____

Telephone: _____

Property Information

Legal Description: _____

P.I.D.: _____

Civic Address of Property: _____

Current Zoning: _____ Current OCP Designation: _____

Tiny House on Wheels Proposal

Accessory (or second) dwelling Primary dwelling

Description of Tiny House and Proposed Site:

Required Plans:

Please submit the following information with this application:

1. A legible site plan, drawn to scale, showing the following:
 - (a) The boundaries and dimensions of the subject property,
 - (b) The location, setbacks and dimensions of the proposed tiny house, porch/deck/stairs and existing buildings,
 - (c) The location of off-street parking, and
 - (d) The location of roads, lanes, pedestrian access routes, screening, landscaping and fencing.
2. Photos of all sides of the tiny house (and proposed skirting/deck/porch/stairs), or if not available, elevation plans showing height, exterior finishing and colour, windows and doors, roof pitch and skirting.

Questionnaire – Tiny House on Wheels Development Permit Area Guidelines:

Please complete the attached questionnaire to help determine if your proposed tiny house on wheels meets the Development Guidelines in the Grand Forks Official Community Plan (OCP).

Please note that upon City Council's approval of this application, you will require to apply for and obtain a building permit.

Applicant Acknowledgement

I, the undersigned, make this application to the City of Grand Forks, have fulfilled the application requirements, and understand that this application is subject to the *Freedom of Information and Protection of Privacy Act* of BC.

Applicant's signature Date

www.grandforks.ca info@grandforks.ca Page 2 of 4

**Applicant Questionnaire
Tiny House on Wheels Development Permit Area Guidelines**

Tiny houses on wheels must consider the guidelines specified in the Official Community Plan. The questions below are based on these guidelines and your answers will help with the review of your proposal.

The Tiny House

1. Is the tiny house oriented to maximize opportunities for passive solar heating and natural lighting?
 Yes No
 Please explain: _____

2. Does the proposed tiny house consider adaptable design and universal accessibility (i.e., is it wheelchair accessible)? Yes No
 Please explain: _____

3. Does the tiny house have natural ventilation and cooling systems? Yes No
 Please explain: _____

4. Does the tiny house consider the use of green roof systems to reduce stormwater runoff, reduce energy costs and improve visual appearance? Yes No
 Please explain: _____

5. Is the tiny house made with building products that demonstrate re-use, upcycling and green technologies?
 Yes No
 Please explain: _____

6. Developments are encouraged to seek Passive House, LEED, or other sustainability certification. Will your tiny house include any of these considerations? Yes No
 Please explain: _____

7. Are you proposing a garage or carport? Yes No
 If so, it should be recessed within the building or set back from the front face of the tiny house.

8. Tiny houses should be clad with durable, aesthetically acceptable and environmentally friendly materials at least as good of quality as the primary dwelling unit (if applicable); vinyl and aluminum siding are not acceptable. What type of cladding or siding will your tiny house have? _____

9. Tiny houses on wheels must be skirted with a finished insulating material the same quality as or complementary to the cladding of the tiny house. Do you agree to skirt your tiny house? Yes No

10. Tiny houses on wheels must have a deck or porch attached, with appropriate stairs or ramp, to signify that they are semi-permanent in nature. Will your tiny house include a deck or porch and stairs?
 Yes No
 Please explain: _____

Utilities / Servicing

11. If the tiny house is an accessory or second dwelling on the lot, it must share the services of the primary dwelling unit as per the City Bylaws for water, sewer and electrical services. How are you proposing to service the tiny house with water, sewer and electricity?

Parking / Access

12. Entrances should face the street (or laneway, if sited on a lane) and have direct pedestrian access from the street. Windows should provide "eyes on the lane" for security. Does your tiny house face the street or lane? Yes No

13. Shared driveways (if applicable) are encouraged to reduce paved surfaces. If a rear lane is available, vehicle access should be off the lane. What kind of driveway will access your tiny house?

Screening and Landscaping

14. Does your tiny house and the primary residence both have at least 9 square metres (97 square feet) of private outdoor space? Yes No

15. Clotheslines are encouraged; will you provide one for the tiny house? Yes No

16. Tiny houses should limit the use of potable water for landscape irrigation. Do you propose to use any of the following measures to provide natural filtration of rainwater on the site?
 Rain gardens
 Rainwater collection systems
 Bio swales
 Permeable paving or crushed rock for driveways

Thank you for providing information about your tiny house on wheels.
If you have any questions, please contact City staff at (250) 442-8266 or info@grandforks.ca.

Appendix F: Quixote Village— Funders and budget breakdown

Funding breakdown (2018) for Quixote Village in Olympia, Washington. For more on this case study, see page 111 in this report.

CAPITAL SOURCES	
State housing trust fund	\$1,550,000
US Department of Housing and Urban Development CDBG	\$699,000
Value of Thurston county land donation	\$333,000
Thurston county grant	\$170,000
Private grants and donations	\$304,000
Total sources	\$3,056,000

CAPITAL EXPENSES	
Land and title	\$337,326
Construction, buildings	\$1,520,742
Construction, site work	\$480,918
Architecture and engineering	\$208,397
Developer fee (community frameworks)	\$170,000
Legal	\$36,000
Permits, fees and hookups	\$94,812
Loan fees	\$34,000
Miscellaneous	\$23,405
Capitalized reserves	\$150,000
Total expenses	\$3,055,600

TENANT RENTS (NON-SECTION 8 UNITS)	
Section 8 HAP contract (up to 25 units)	\$128,250
State operating and maintenance trust fund	\$50,000
Tenant rents (non-Section 8 units)	\$6,000
Thurston county	\$50,000
Private donations	\$12,600
Total operating & service sources	\$246,850

OPERATING & SERVICES EXPENSES	
Program manager (incl. taxes and benefits)	\$67,500
Resident advocates (incl. taxes and benefits)	\$52,500
Utilities	\$38,100
Repairs and maintenance	\$26,000
Insurance	\$15,175
Accounting and audit	\$13,300
Misc. office expense	\$7,775
Resident services	\$13,000
Reserve contributions	\$13,500
Total operating and service expenses	\$246,850

Appendix G:

District of Squamish— Post-workshop comments and questions

Below are questions and comments that arose from the internal workshop hosted at the District of Squamish in June 2018:

- › Will the district allow multiple units on one site? CSA standards identify spacing requirements from other units to meet fire codes.
- › Which of the CSA standards meet Step Code #1? If none do, what requirements must be met so it does?
- › How long would it take to do a Development Permit (DP) and building permit? Could it be expedited? Concerned that time may be a hindrance to uptake if too long.
- › Will you require a DP and building permit for the pad and servicing, or every time a new tenant parks on the pad?
- › If skirting and anchoring are required, how long does the renter have to set it up? How long after the house is parked would an inspection, if required, occur?
- › How will skirting and/or anchoring be enforced?
- › What will be the cost to service and for all permits, for the homeowner and renter?
- › Who requires a permit? The homeowner (for the pad and servicing) and the renter (for the unit)? Or just the homeowner?
- › Require guidelines on how to set up hookups, for instance, insulation and angles for flow; who's liable if the hookup isn't installed properly?
- › Will tiny homeowners require insurance (property and fire) to park in someone's backyard?
- › Does the placement of the house and servicing hookups matter? Will they be universal for all tiny homes? Should all hookups include propane and gas to ensure they can service more homes?
- › The homeowner offers the pad for rent at a set price through online and/or print posts; once the tiny house is on the pad and hooked-up, will it require an inspection by an engineer (could include a review of the skirting and anchoring at this time)? How is this done in RV and mobile home parks?
- › The permeability of the site. Do driveways need to be paved?
- › Are compost toilets allowed? If so, what are the guidelines for use? How will these units/waste be managed and not attract animals? Is there an additional permit/annual fee to the renter if a compost toilet is used?
- › Two possible proposed approaches:
 - › Homeowner wants a pad; applies for a DP and building permit; chooses a pad type (maybe a few material options but width and length are set) and servicing hookups (water, sewer, electric [these three are mandatory], and gas/propane if desired); pad and servicing are inspected for a fee and an occupancy permit is issued; requires an annual fee (or whatever is done with secondary suites). Now a District of Squamish certified tiny house landlord.
 - › Mobile tiny homeowner provides the city or an intermediate (possibly a tiny house advocate agency) with CSA or other equivalent standards (including American) documentation to review, and ensure all requirements set by the district are met; a tiny house license is issued; could require renewal (to encourage maintenance of home). Now a District of Squamish certified tiny homeowner.



Research Centre

1701-4555 Kingsway

Burnaby, BC V5H 4V8

Phone: 604 439 4135

Toll-free: 1 866 465 6873

Email: technicalresearch@bchousing.org

www.bchousing.org